

## **PET4I101 ELECTROMAGNETICS ENGINEERING (4<sup>th</sup> Sem ECE-ETC)**

### **Module-I (10 Hours)**

1. Cartesian, Cylindrical and Spherical Coordinate Systems; Scalar and Vector Fields; Line, Surface and Volume Integrals.

2. Coulomb's Law; The Electric Field Intensity; Electric Flux Density and Electric Flux;

Gauss's Law; Divergence of Electric Flux Density: Point Form of Gauss's Law; The Divergence Theorem; The Potential Gradient; Energy Density; Poisson's and Laplace's Equations.

3. Ampere's Magnetic Circuital Law and its Applications; Curl of H; Stokes' Theorem; Divergence of B; Energy Stored in the Magnetic Field.

### **Module-II (8 Hours)**

1. The Continuity Equation; Faraday's Law of Electromagnetic Induction; Conduction

Current: Point Form of Ohm's Law, Convection Current; The Displacement Current;

2. Maxwell's Equations in Differential Form; Maxwell's Equations in Integral Form; Maxwell's Equations for Sinusoidal Variation of Fields with Time; Boundary Conditions; The Retarded Potential; The Poynting Vector; Poynting Vector for Fields Varying Sinusoid ally with Time

### **Module-III (8 Hours)**

1. Solution of the One-Dimensional Wave Equation; Solution of Wave Equation for Sinusoid ally Time-Varying Fields; Polarization of Uniform Plane Waves; Fields on the Surface of a Perfect Conductor; Reflection of a Uniform Plane Wave Incident Normally on a Perfect Conductor and at the Interface of Two Dielectric Regions; The Standing Wave Ratio; Oblique Incidence of a Plane Wave at the Boundary between Two Regions; Oblique Incidence of a Plane Wave on a Flat Perfect Conductor and at the Boundary between Two Perfect Dielectric Regions;

### **Module-IV (8 Hours)**

1. Types of Two-Conductor Transmission Lines; Circuit Model of a Uniform Two-

Conductor Transmission Line; The Uniform Ideal Transmission Line; Wave Reflection at a Discontinuity in an Ideal Transmission Line; Matching of Transmission Lines with Load.

**Additional Module (Terminal Examination-Internal) (8 Hours)**

1. Formulation of Field Equations; Wave Types; the Parallel-Plate Waveguide; the Rectangular Waveguide.
2. Radiation Properties of a Current Element; Radiation Properties of a Half-Wave Dipole; Yagi-Uda Antenna; the Parabolic Reflector Antenna.
3. The Vector Magnetic Potential; Energy stored in a capacitor, Graphical field mapping; Continuity of Current in a Capacitor; Critical Angle of Incidence and Total Reflection; Brewster Angle.

**EI3I001 ELECTROMAGNETIC FIELD THEORY (3<sup>rd</sup> Sem I&E Engg.)**

**MODULE – I (13 Hours)**

**1. Vectors and Fields:** Cartesian Coordinate System, Cylindrical and Spherical coordinate system, Vector Algebra, Scalar and Vector Fields, gradient, divergence, curl operations, The Laplacian, Divergence Theorem, Stoke's Theorem, Useful vector identities and their derivations.

(selected portions from 1.01 to 1.05 of TB-1)

**2.: Electric and Magnetic fields:** Field due to a line/sheet/volume charge, Biot-Savart

Law, Gauss's Law for Electric Field and Magnetic Field, Fields of electric and magnetic dipoles,

Applications of electrostatics and magnetostatics, Faraday's Law, Ampere's Circuital Law.

(portions 3.4.to 3.6, 4.4.3,4.6, 4.8,4.9, 8.3 to 8.8 and 9.2 of TB-2)

**3. Maxwell's Equations:** Divergence and Differential Form, Line Integral, Surface Integral and

Integral form, Faradays Law, Ampere's Circuital Law, Gauss's Law for Electric Field and

Magnetic Field. (portions 4.01 to 4.03 of TB-1)

**MODULE – II (13 Hours)** (Portions 5.01 to 5.13 of TB-1)

**4. Wave Propagation in Free Space:** The electromagnetic wave equation and its solution,

Uniform Plane Waves, Direction cosines, Concept on TEM mode, Poynting Vector and Power density

**5. Wave Propagation in Material Media:** Conductors and Dielectrics, Magnetic Materials, Wave

Equation and Solution, Uniform Plane Waves in Dielectrics and Conductors, Polarization, Boundary Conditions, Reflection and Transmission of Uniform Plane Waves at the boundary of two media for normal and oblique incidence, Brewster's angle.

**MODULE – III (10 Hours)**

**6. Transmission Line Analysis:** Transmission lines, Circuit representation of a parallel plane transmission line, Parallel plane transmission lines with loss, E and H about long parallel cylindrical conductors of arbitrary cross section, Transmission line theory, UHF lines as circuit elements (portions 7.10 to 7.16 of TB-1)

**7. Wave Guide Principles:** Rectangular guides, TM waves in rectangular guides, TE waves in rectangular guides, Impossibility of TEM wave in wave guides, wave impedance and characteristic impedances, Attenuation factor and Q of wave guides, Dielectric Slab Guide, (portions 8.01 to 8.04, 8.08,8.10,8.11 of TB-1)

**PET6J012 ANTENNAS & WAVE PROPAGATION (6<sup>th</sup> Sem ECE-ETC)**

**MODULE- I**

**Electromagnetic radiation and antenna fundamentals-** Review of electromagnetic theory: Vector potential, Solution of wave equation, retarded case, Hertzian dipole. Antenna characteristics: Radiation pattern, Beam solid angle, Directivity, Gain, Input impedance, Polarization, Bandwidth, Reciprocity, Equivalence of Radiation patterns, Equivalence of Impedances, Effective aperture, Vector effective length, Antenna temperature.

**MODULE-II**

**Wire antennas-** Short dipole, Radiation resistance and Directivity, Half wave Dipole, Monopole, Small loop antennas. Antenna Arrays: Linear Array and Pattern Multiplication, Two-element Array, Uniform Array, Polynomial representation, Array with non-uniform Excitation-Binomial Array

**MODULE- III**

**Aperture Antennas-** Magnetic Current and its fields, Uniqueness theorem, Field equivalence principle, Duality principle, Method of Images, Pattern properties, Slot antenna, Horn Antenna, Pyramidal Horn Antenna, Reflector Antenna-Flat reflector, Corner Reflector, Common curved reflector shapes, Lens Antenna

## **MODULE- IV**

**Special Antennas**-Long wire, V and Rhombic Antenna, Yagi-Uda Antenna, Turnstile

Antenna, Helical Antenna- Axial mode helix, Normal mode helix, Biconical Antenna, Log

periodic Dipole Array, Spiral Antenna, Microstrip Patch Antennas.

**Antenna Measurements**- Radiation Pattern measurement, Gain and Directivity Measurements, Anechoic Chamber measurement.

### **ADDITIONAL MODULE (TERMINAL EXAMINATION-INTERNAL)**

**Radio wave propagation**- Calculation of Great Circle Distance between any two points on

earth, Ground Wave Propagation, Free-space Propagation, Ground Reflection, Surface

waves, Diffraction, Wave propagation in complex Environments, Tropospheric Propagation,

Tropospheric Scatter. Ionospheric propagation: Structure of ionosphere, Sky waves, skip

distance, Virtual height, Critical frequency, MUF, Electrical properties of ionosphere, Effects

of earth's magnetic fields, Faraday rotation, Whistlers.

## **PEL3I001 ELECTROMAGNETIC THEORY (3<sup>rd</sup> Sem EEE)**

### **Module – I (8 hours)**

#### **University Portion (80%):**

Co-ordinate systems & Transformation: Cartesian co-ordinates, circular cylindrical co-ordinates,

spherical co-ordinates.

Vector Calculus: Differential length, Area & volume, Line surface and volume Integrals, Del

operator, Gradient of a scalar, Divergence of a vector & divergence theorem, curl of a vector &

Stoke's theorem, laplacian of a scalar (Text Book 1: Chapter- 1, Chapter-2)

#### **College/Institute Portion (20%):**

Field: Scalar Field and Vector Field. Or related advanced topics as decided by the concerned faculty

teaching the subject.

### **Module – II (11 hours)**

#### **University Portion (80%):**

Electrostatic Fields: Coulomb's Law, Electric Field Intensity, Electric Fields due to point, line,

surface and volume charge, Electric Flux Density, Gauss's Law – Maxwell's Equation, Applications

of Gauss's Law, Electric Potential, Relationship between E and V –Maxwell's Equation An Electric

Dipole & Flux Lines, Energy Density in Electrostatic Fields., Electrostatic Boundary – Value

Problems: Poisson's & Laplace's Equations, Uniqueness theorem, General procedures for solving

Poisson's or Laplace's Equation. (Textbook-1: Chapter- 3, 4, 5.1 to 5.5)

**College/Institute Portion (20%):**

Nature of current and current density, the equation of continuity. Or related advanced topics as

decided by the concerned faculty teaching the subject.

**Module – III (8 hours)**

**University Portion (80%):**

Magnetostatic Fields: Magnetic Field Intensity, Biot-Savart's Law, Ampere's circuit law-Maxwell

Equation, applications of Ampere's law, Magnetic Flux Density-Maxwell's equations. Maxwell's

equation for static fields, Magnetic Scalar and Vector potentials. (Textbook-1:

Chapter- 6.1 to 6.8)

**College/Institute Portion (20%): (2 hours)**

Energy in Magnetic Field Or related advanced topics as decided by the concerned faculty teaching the subject.

**Module – IV (7 hours)**

**University Portion (80%):**

Electromagnetic Fields and Wave Propagation: Faraday's Law, Transformer & Motional Electromagnetic Forces, Displacement Current, Maxwell's Equation in Final forms, Time Varying

Potentials, Time-Harmonic Field. Electromagnetic Wave Propagation: Wave Propagation in lossy

Dielectrics, Plane Waves in loss less Dielectrics, Power & pointing vector. (Textbook-1: Chapter-8.1

to 8.7, Ch.9.1 to 9.3 & 9.6)

**College/Institute Portion (20%):**

General Wave Equation, Plane wave in dielectric medium, free space, a conducting medium, a good

conductor and good dielectric, Polarization of wave. Or related advanced topics as decided by the

concerned faculty teaching the subject.

## MODULE-I

### Elementary Coordinate Systems

We know that the cylindrical coordinates are given by  $(\rho, \phi, z)$ . Basically, the  $xy$ -plane is transformed into polar coordinates while the  $z$ -axis remains the same in both the cylindrical and the rectangular system of coordinates. We solve a couple of numerical to explain the basics of the three orthogonal coordinate systems, namely, rectangular, cylindrical and spherical.

**Ex.1.1** Relate the differentials in cylindrical coordinates to the rectangular coordinates.

$$x = \rho \cos \phi \quad y = \rho \sin \phi \quad \rho = \sqrt{x^2 + y^2}, \quad \tan \phi = \frac{y}{x}$$

$$\frac{\partial}{\partial x} = \cos \phi \frac{\partial}{\partial \rho} - \frac{\sin \phi}{\rho} \frac{\partial}{\partial \phi}$$

$$\frac{\partial}{\partial y} = \sin \phi \frac{\partial}{\partial \rho} + \frac{\cos \phi}{\rho} \frac{\partial}{\partial \phi}$$

$$A_x = A_\rho \cos \phi - A_\phi \sin \phi$$

$$A_y = A_\rho \sin \phi + A_\phi \cos \phi$$

**Ex.1.2** Compute  $\nabla \cdot \mathbf{A} = \frac{\partial A_x}{\partial x} + \frac{\partial A_y}{\partial y} + \frac{\partial A_z}{\partial z}$  in cylindrical coordinates

**Soln:** Substitution of the results in Ex. 1.1 in the above expression gives us

$$\begin{aligned} \nabla \cdot \mathbf{A} &= \left( \cos \phi \frac{\partial}{\partial \rho} - \frac{\sin \phi}{\rho} \frac{\partial}{\partial \phi} \right) (A_\rho \cos \phi - A_\phi \sin \phi) \\ &+ \left( \sin \phi \frac{\partial}{\partial \rho} + \frac{\cos \phi}{\rho} \frac{\partial}{\partial \phi} \right) (A_\rho \sin \phi + A_\phi \cos \phi) + \frac{\partial A_z}{\partial z} \end{aligned}$$

This is equal to

$$\begin{aligned} \nabla \cdot \mathbf{A} &= \cos^2 \phi \frac{\partial A_\rho}{\partial \rho} - \frac{\sin \phi (-\sin \phi)}{\rho} A_\rho + \frac{\sin^2 \phi}{\rho} \frac{\partial A_\phi}{\partial \phi} \\ &+ \sin^2 \phi \frac{\partial A_\rho}{\partial \rho} + \frac{\cos \phi}{\rho} A_\rho \cos \phi + \frac{\cos^2 \phi}{\rho} \frac{\partial A_\phi}{\partial \phi} + \frac{\partial A_z}{\partial z} \end{aligned}$$

Therefore,

$$\begin{aligned}
\nabla \cdot \mathbf{A} &= (\cos^2 \phi + \sin^2 \phi) \frac{\partial A_\rho}{\partial \rho} + \left( \frac{\sin^2 \phi}{\rho} + \frac{\cos^2 \phi}{\rho} \right) A_\rho + \left( \frac{\cos^2 \phi}{\rho} + \frac{\sin^2 \phi}{\rho} \right) \frac{\partial A_\phi}{\partial \phi} + \frac{\partial A_z}{\partial z} \\
&= \frac{\partial A_\rho}{\partial \rho} + \frac{A_\rho}{\rho} + \frac{\partial A_\phi}{\rho \partial \phi} + \frac{\partial A_z}{\partial z} \\
&= \frac{1}{\rho} \frac{\partial}{\partial \rho} (\rho A_\rho) + \frac{\partial A_\phi}{\rho \partial \phi} + \frac{\partial A_z}{\partial z}
\end{aligned}$$

**Ex 1.3.** Transform the equation  $\frac{\partial^2 \Psi}{\partial x^2} + \frac{\partial^2 \Psi}{\partial y^2} = 0$  into polar coordinates.

**Soln:** We know  $x = \rho \cos \phi$   $y = \rho \sin \phi$   $\rho = \sqrt{x^2 + y^2}$ ,  $\phi = \tan^{-1} \frac{y}{x}$

$$\text{Hence, } \frac{\partial \rho}{\partial x} = \frac{1}{2} (x^2 + y^2)^{-1/2} \cdot 2x = \frac{x}{\sqrt{x^2 + y^2}} = \frac{\rho \cos \phi}{\rho} = \cos \phi$$

$$\text{And } \frac{\partial \phi}{\partial x} = \frac{\partial}{\partial x} \left( \tan^{-1} \frac{y}{x} \right) = \frac{1}{1 + \left( \frac{y}{x} \right)^2} \cdot \left( -\frac{y}{x^2} \right) = -\frac{y}{x^2 + y^2} = -\frac{\rho \sin \phi}{\rho^2} = -\frac{\sin \phi}{\rho}$$

Thus,

$$\frac{\partial}{\partial x} = \cos \phi \frac{\partial}{\partial \rho} - \frac{\sin \phi}{\rho} \frac{\partial}{\partial \phi}$$

$$\frac{\partial}{\partial y} = \sin \phi \frac{\partial}{\partial \rho} + \frac{\cos \phi}{\rho} \frac{\partial}{\partial \phi}$$

$$\text{Thus } \frac{\partial \Psi}{\partial x} = \frac{\partial \Psi}{\partial \rho} \cdot \frac{\partial \rho}{\partial x} + \frac{\partial \Psi}{\partial \phi} \cdot \frac{\partial \phi}{\partial x} = \cos \phi \frac{\partial \Psi}{\partial \rho} - \frac{\sin \phi}{\rho} \frac{\partial \Psi}{\partial \phi}$$

Therefore,

$$\begin{aligned}
\frac{\partial^2 \Psi}{\partial x^2} &= \frac{\partial}{\partial x} \left( \frac{\partial \Psi}{\partial x} \right) = \left( \cos \phi \frac{\partial}{\partial \rho} - \frac{\sin \phi}{\rho} \frac{\partial}{\partial \phi} \right) \left( \cos \phi \frac{\partial \Psi}{\partial \rho} - \frac{\sin \phi}{\rho} \frac{\partial \Psi}{\partial \phi} \right) \\
&= \cos^2 \phi \frac{\partial^2 \Psi}{\partial \rho^2} - \frac{\cos \phi \sin \phi}{\rho} \frac{\partial^2 \Psi}{\partial \rho \partial \phi} - \frac{\sin \phi \cos \phi}{\rho} \frac{\partial^2 \Psi}{\partial \rho \partial \phi} + \frac{\sin^2 \phi}{\rho^2} \frac{\partial^2 \Psi}{\partial \phi^2} \\
&\quad - \cos \phi \sin \phi \frac{\partial \Psi}{\partial \phi} \frac{\partial}{\partial \rho} \left( \frac{1}{\rho} \right) - \sin \phi \cos \phi \frac{\partial \Psi}{\partial \phi} \frac{\partial}{\partial \rho} \left( \frac{1}{\rho} \right) - \frac{\sin \phi}{\rho} \frac{\partial}{\partial \phi} (\cos \phi) \frac{\partial \Psi}{\partial \rho} \\
&= \cos^2 \phi \frac{\partial^2 \Psi}{\partial \rho^2} - 2 \frac{\cos \phi \sin \phi}{\rho} \frac{\partial^2 \Psi}{\partial \rho \partial \phi} + \frac{\sin^2 \phi}{\rho^2} \frac{\partial^2 \Psi}{\partial \phi^2} - 2 \cos \phi \sin \phi \left( -\frac{1}{\rho^2} \right) - \frac{\sin \phi}{\rho} (-\sin \phi) \frac{\partial \Psi}{\partial \rho} \\
&= \cos^2 \phi \frac{\partial^2 \Psi}{\partial \rho^2} - 2 \frac{\cos \phi \sin \phi}{\rho} \frac{\partial^2 \Psi}{\partial \rho \partial \phi} + \frac{\sin^2 \phi}{\rho^2} \frac{\partial^2 \Psi}{\partial \phi^2} + \frac{2 \cos \phi \sin \phi}{\rho^2} \frac{\partial \Psi}{\partial \rho} + \frac{\sin^2 \phi}{\rho} \frac{\partial \Psi}{\partial \rho}
\end{aligned}$$

Similarly,

$$\begin{aligned}
\frac{\partial^2 \Psi}{\partial y^2} &= \frac{\partial}{\partial y} \left( \frac{\partial \Psi}{\partial y} \right) = \left( \sin \phi \frac{\partial}{\partial \rho} + \frac{\cos \phi}{\rho} \frac{\partial}{\partial \phi} \right) \left( \sin \phi \frac{\partial \Psi}{\partial \rho} + \frac{\cos \phi}{\rho} \frac{\partial \Psi}{\partial \phi} \right) \\
&= \sin^2 \phi \frac{\partial^2 \Psi}{\partial \rho^2} + \frac{\cos \phi \sin \phi}{\rho} \frac{\partial^2 \Psi}{\partial \rho \partial \phi} + \frac{\cos \phi}{\rho} \frac{\partial}{\partial \phi} (\sin \phi) \frac{\partial \Psi}{\partial \rho} + \frac{\sin \cos \phi}{\rho} \frac{\partial^2 \Psi}{\partial \rho \partial \phi} \\
&\quad + \frac{\cos^2 \phi}{\rho^2} \frac{\partial^2 \Psi}{\partial \phi^2} + \sin \phi \cos \phi \frac{\partial}{\partial \rho} \left( \frac{1}{\rho} \right) \frac{\partial \Psi}{\partial \phi} + \cos \phi \sin \phi \frac{\partial}{\partial \rho} \left( \frac{1}{\rho} \right) \frac{\partial \Psi}{\partial \phi} \\
&= \sin^2 \phi \frac{\partial^2 \Psi}{\partial \rho^2} + 2 \frac{\cos \phi \sin \phi}{\rho} \frac{\partial^2 \Psi}{\partial \rho \partial \phi} + \frac{\cos^2 \phi}{\rho} \frac{\partial \Psi}{\partial \rho} - 2 \frac{\sin \phi \cos \phi}{\rho^2} \frac{\partial \Psi}{\partial \phi} + \frac{\cos^2 \phi}{\rho^2} \frac{\partial^2 \Psi}{\partial \phi^2}
\end{aligned}$$

Adding the two terms, we get

$$\begin{aligned}
\frac{\partial^2 \Psi}{\partial x^2} + \frac{\partial^2 \Psi}{\partial y^2} &= \cos^2 \phi \frac{\partial^2 \Psi}{\partial \rho^2} - 2 \frac{\cos \phi \sin \phi}{\rho} \frac{\partial^2 \Psi}{\partial \rho \partial \phi} + \frac{\sin^2 \phi}{\rho^2} \frac{\partial^2 \Psi}{\partial \phi^2} + \frac{2 \cos \phi \sin \phi}{\rho^2} \frac{\partial \Psi}{\partial \phi} + \frac{\sin^2 \phi}{\rho} \frac{\partial \Psi}{\partial \rho} + \\
&\quad \sin^2 \phi \frac{\partial^2 \Psi}{\partial \rho^2} + 2 \frac{\cos \phi \sin \phi}{\rho} \frac{\partial^2 \Psi}{\partial \rho \partial \phi} + \frac{\cos^2 \phi}{\rho} \frac{\partial \Psi}{\partial \rho} - 2 \frac{\sin \phi \cos \phi}{\rho^2} \frac{\partial \Psi}{\partial \phi} + \frac{\cos^2 \phi}{\rho^2} \frac{\partial^2 \Psi}{\partial \phi^2} \\
&= (\cos^2 \phi + \sin^2 \phi) \frac{\partial^2 \Psi}{\partial \rho^2} + \left( \frac{\sin^2 \phi}{\rho} + \frac{\cos^2 \phi}{\rho} \right) \frac{\partial \Psi}{\partial \rho} + \frac{\sin^2 \phi}{\rho^2} \frac{\partial^2 \Psi}{\partial \phi^2} + \frac{\cos^2 \phi}{\rho^2} \frac{\partial^2 \Psi}{\partial \phi^2} \\
&= \frac{\partial^2 \Psi}{\partial \rho^2} + \frac{1}{\rho} \frac{\partial \Psi}{\partial \rho} + \frac{\partial^2 \Psi}{\rho^2 \partial \phi^2} \\
&= \frac{1}{\rho} \frac{\partial}{\partial \rho} \left( \rho \frac{\partial \Psi}{\partial \rho} \right) + \frac{\partial^2 \Psi}{\rho^2 \partial \phi^2}
\end{aligned}$$

**Ex. 1.4** Derive a suitable expression for  $\frac{\partial \Psi}{\partial x}$  in cylindrical coordinates.

**Soln:** We have

$$x = \rho \cos \phi \quad y = \rho \sin \phi \quad \rho = \sqrt{x^2 + y^2}, \quad \phi = \tan^{-1} \frac{y}{x}$$

$$\frac{\partial \Psi}{\partial x} = \frac{\partial \Psi}{\partial \rho} \frac{\partial \rho}{\partial x}$$

$$\text{Now, } \frac{\partial \rho}{\partial x} = \frac{1}{2} (x^2 + y^2)^{-\frac{1}{2}} \cdot 2x = \frac{x}{\sqrt{x^2 + y^2}} = \frac{\rho \cos \phi}{\rho} = \cos \phi$$



$$\begin{aligned}
\frac{\partial \Psi}{\partial x} &= \frac{\partial \Psi}{\partial \rho} \frac{\partial \rho}{\partial x} = \cos \phi \frac{\partial \Psi}{\partial \rho} \\
\Rightarrow \frac{\partial^2 \Psi}{\partial x^2} &= \frac{\partial}{\partial x} \left( \frac{\partial \Psi}{\partial x} \right) = \frac{\partial}{\partial x} \left( \frac{\partial \Psi}{\partial \rho} \cdot \frac{\partial \rho}{\partial x} \right) \\
&= \frac{\partial \Psi}{\partial \rho} \frac{\partial^2 \rho}{\partial x^2} + \frac{\partial \rho}{\partial x} \frac{\partial^2 \Psi}{\partial x \partial \rho} \\
\frac{\partial^2 \rho}{\partial x^2} &= \frac{\sqrt{x^2 + y^2} - \frac{1}{2} x (x^2 + y^2)^{-\frac{1}{2}} \cdot 2x}{x^2 + y^2} \\
&= \frac{1}{\sqrt{x^2 + y^2}} - \frac{x^2}{(x^2 + y^2)^{\frac{3}{2}}} \\
\text{Now, } &= \frac{1}{\rho} - \frac{\rho^2 \cos^2 \phi}{\rho^3} \\
&= \frac{1}{\rho} (1 - \cos^2 \phi) \\
&= \frac{1}{\rho} \sin^2 \phi
\end{aligned}$$

Substitution of this in the above gives us

$$\begin{aligned}
\frac{\partial \Psi}{\partial x} &= \frac{\partial \Psi}{\partial \rho} \frac{\partial^2 \rho}{\partial x^2} + \frac{\partial \rho}{\partial x} \frac{\partial^2 \Psi}{\partial x \partial \rho} \\
&= \frac{\sin^2 \phi}{\rho} \frac{\partial \Psi}{\partial \rho} + \cos \phi \frac{\partial}{\partial \rho} \left( \frac{\partial \Psi}{\partial x} \right) \\
&= \frac{\sin^2 \phi}{\rho} \frac{\partial \Psi}{\partial \rho} + \cos \phi \cdot \frac{\partial}{\partial \rho} \left( \cos \phi \frac{\partial \Psi}{\partial \rho} \right) \\
&= \frac{\sin^2 \phi}{\rho} \frac{\partial \Psi}{\partial \rho} + \cos^2 \phi \frac{\partial^2 \Psi}{\partial \rho^2} \\
&= \cos^2 \phi \frac{\partial^2 \Psi}{\partial \rho^2} + \frac{\sin^2 \phi}{\rho} \frac{\partial \Psi}{\partial \rho}
\end{aligned}$$

**Ex. 1.5** For a spherical wave, the displacement  $\Psi$  is a function of  $r$  and  $t$  where  $r$  is the magnitude of the distance from a fixed point. Obtain a general equation for the spherical wave.

**Soln:** We need to show the following

$$\nabla^2 \Psi = \frac{\partial^2 \Psi}{\partial r^2} + \frac{2}{r} \frac{\partial \Psi}{\partial r} = \frac{1}{r^2} \frac{\partial}{\partial r} \left( r^2 \frac{\partial \Psi}{\partial r} \right)$$

We understand that

$$\frac{\partial \Psi}{\partial x} = \frac{\partial \Psi}{\partial r} \frac{\partial r}{\partial x}$$

$$r^2 = x^2 + y^2 + z^2$$

$$\Rightarrow 2r \frac{\partial r}{\partial x} = 2x$$

Now,

$$\Rightarrow \frac{\partial r}{\partial x} = \frac{x}{r}$$

$$\Rightarrow \frac{\partial \Psi}{\partial x} = \frac{\partial \Psi}{\partial r} \frac{x}{r}$$

Let us go for the second order differential which is obtained by differentiating the above function once more with respect to  $x$ . Thus,

$$\frac{\partial^2 \Psi}{\partial x^2} = \frac{\partial}{\partial x} \left( \frac{\partial \Psi}{\partial x} \right) = \frac{\partial}{\partial x} \left( \frac{\partial \Psi}{\partial r} \frac{x}{r} \right) = \frac{\partial}{\partial x} \left( \frac{\partial \Psi}{\partial r} \right) \frac{x}{r} + \frac{\partial}{\partial x} \left( \frac{x}{r} \right) \frac{\partial \Psi}{\partial r}$$

$$= \frac{\partial}{\partial r} \left( \frac{\partial \Psi}{\partial r} \right) \frac{\partial r}{\partial x} \frac{x}{r} + \frac{1}{r} \frac{\partial \Psi}{\partial r}$$

$$= x \frac{\partial}{\partial r} \left( \frac{1}{r} \frac{\partial \Psi}{\partial r} \right) \frac{\partial r}{\partial x} + \frac{1}{r} \frac{\partial \Psi}{\partial r}$$

$$= x \frac{x}{r} \frac{\partial}{\partial r} \left( \frac{1}{r} \frac{\partial \Psi}{\partial r} \right) + \frac{1}{r} \frac{\partial \Psi}{\partial r}$$

$$= \frac{x^2}{r} \left( \frac{1}{r} \frac{\partial^2 \Psi}{\partial r^2} - \frac{1}{r^2} \frac{\partial \Psi}{\partial r} \right) + \frac{1}{r} \frac{\partial \Psi}{\partial r}$$

$$= \frac{1}{r} \frac{\partial \Psi}{\partial r} + \frac{x^2}{r^2} \frac{\partial^2 \Psi}{\partial r^2} - \frac{x^2}{r^3} \frac{\partial \Psi}{\partial r}$$

Similarly, we get for the  $y$  component

$$\frac{\partial^2 \Psi}{\partial y^2} = \frac{\partial}{\partial y} \left( \frac{\partial \Psi}{\partial y} \right) = \frac{1}{r} \frac{\partial \Psi}{\partial r} + \frac{y^2}{r^2} \frac{\partial^2 \Psi}{\partial r^2} - \frac{y^2}{r^3} \frac{\partial \Psi}{\partial r}$$

and for the  $z$  component

$$\frac{\partial^2 \Psi}{\partial z^2} = \frac{1}{r} \frac{\partial \Psi}{\partial r} + \frac{z^2}{r^2} \frac{\partial^2 \Psi}{\partial r^2} - \frac{z^2}{r^3} \frac{\partial \Psi}{\partial r}$$

Therefore,

$$\begin{aligned}
\frac{\partial^2 \Psi}{\partial x^2} + \frac{\partial^2 \Psi}{\partial y^2} + \frac{\partial^2 \Psi}{\partial z^2} &= \frac{1}{r} \frac{\partial \Psi}{\partial r} + \frac{x^2}{r^2} \frac{\partial^2 \Psi}{\partial r^2} - \frac{x^2}{r^3} \frac{\partial \Psi}{\partial r} \\
&+ \frac{1}{r} \frac{\partial \Psi}{\partial r} + \frac{y^2}{r^2} \frac{\partial^2 \Psi}{\partial r^2} - \frac{y^2}{r^3} \frac{\partial \Psi}{\partial r} \\
&+ \frac{1}{r} \frac{\partial \Psi}{\partial r} + \frac{z^2}{r^2} \frac{\partial^2 \Psi}{\partial r^2} - \frac{z^2}{r^3} \frac{\partial \Psi}{\partial r} \\
&= \frac{3}{r} \frac{\partial \Psi}{\partial r} + \frac{(x^2 + y^2 + z^2)}{r^2} \frac{\partial^2 \Psi}{\partial r^2} - \frac{(x^2 + y^2 + z^2)}{r^3} \frac{\partial \Psi}{\partial r} \\
&= \frac{\partial^2 \Psi}{\partial r^2} + \frac{2}{r} \frac{\partial \Psi}{\partial r} \ominus x^2 + y^2 + z^2 = r^2 \\
&= \frac{1}{r^2} \frac{\partial}{\partial r} \left( r^2 \frac{\partial \Psi}{\partial r} \right)
\end{aligned}$$

**Ex 1.6.** Plane  $z = 10$  m carries a surface charge density of  $20 \text{ nc/m}^2$ . What is the electric field at the origin?

**Soln:** The unit normal to the plane of  $z = 10$  m is  $a_z$ . As this is above the origin, the unit normal for the electric field at the origin becomes  $-a_z$ . Thus, the electric field strength becomes

$$E = \frac{\rho_s}{2\epsilon_0} (-a_z) = \frac{20 \times 10^{-9}}{2 \times \frac{1}{36\pi} \times 10^{-9}} (-a_z) = -360\pi a_z \text{ V/m}$$

**Ex 1.7.** Two point charges ( $Q_1=Q, Q_2=2Q$ ) and an infinite ground plane are shown in the following figure. Find the ratio of the forces experienced by both  $Q_1$  and  $Q_2$ .

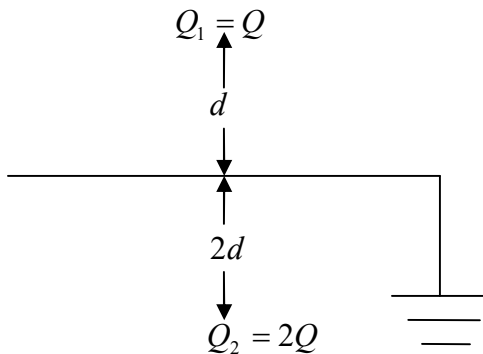

**Soln:** The ground plane acts like a mirror for the two charges and charges of opposite polarity with same magnitude are induced on both sides of the plane. Hence the diagram looks as the following

$$-Q_2 = -2Q$$

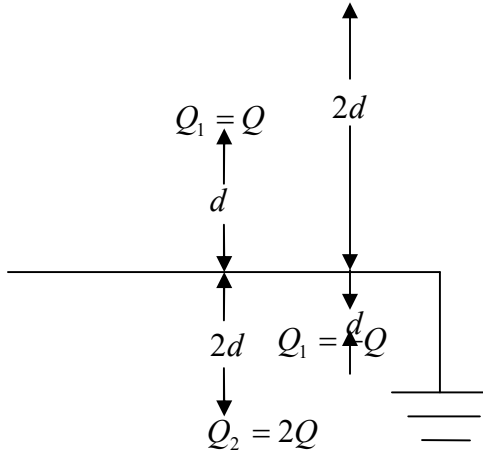

Force experienced by  $Q_1$  would be due to three charges;  $-Q_1$  at  $2d$ ,  $Q_2 = 2Q$  at  $3d$  and  $-Q_2 = -2Q$  at  $d$ . The net force is

$$\begin{aligned}
 F_1 &= \frac{1}{4\pi\epsilon_0} \left[ \frac{Q_1(-Q_1)}{(2d)^2} + \frac{Q_1Q_2}{(3d)^2} + \frac{Q_1(-Q_2)}{(d)^2} \right] \\
 &\Rightarrow \frac{1}{4\pi\epsilon_0} \left[ \frac{Q(-Q)}{4d^2} + \frac{Q \cdot 2Q}{9d^2} + \frac{Q(-2Q)}{d^2} \right] \\
 &= \frac{1}{4\pi\epsilon_0} \cdot \frac{Q^2}{d^2} \left( \frac{2}{9} - \frac{1}{4} - 2 \right) \\
 &= -\frac{1}{4\pi\epsilon_0} \cdot \frac{Q^2}{d^2} \cdot \frac{73}{36}
 \end{aligned}$$

**Ex 1.8.** The electric field strength at a distance point, P, due to a point charge,  $+q$  located on the origin, is  $100 \text{ V/m}$ . If the point charge is now enclosed by a perfectly conducting metal sheet sphere whose centre is at the origin, compute the electric field strength outside the sphere.

**Soln:** With a conducting metal sheet surrounding the point charge  $+q$ , equal and opposite charges are induced in inner and outer surfaces of the sphere. The net charge enclosed by Gaussian surface of radius ' $r$ ' is again  $+q$ . Thus,

$$\oint \mathbf{D} \cdot d\mathbf{s} = q$$

$$\Rightarrow D = \frac{q}{4\pi r^2}$$

$$\Rightarrow E = \frac{q}{4\pi\epsilon_0 r^2}$$

Thus, the electric field is same with and without the conducting sphere.

**Ex 1.9.** A straight current carrying conductor and two conducting loops A and B are shown in the following diagram. What are the directions of the induced currents in A and B if the current in the straight conductor is decreasing?

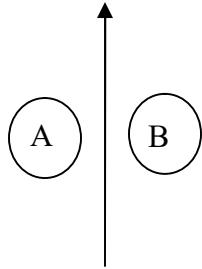

**Soln:** The direction of the current as shown produces a magnetic field in the anticlockwise direction that encircles the straight wire. It becomes anticlockwise in B whereas A has clockwise encircled magnetic flux. If the current is decreasing in the straight conductor, the induced currents in the loops would be in such a direction so as to oppose this change. Hence, B would get a current in the clockwise direction and A would have its induced current in the anticlockwise direction.

**Ex 1.10** In spherical coordinates region 1 is  $r < a$ , region 2 is  $a < r < b$  and region 3 is  $r > b$ . Regions 1 and 3 are free space, while  $\mu_{r2} = 500$ . Given  $\mathbf{B}_1 = 0.20\hat{r}$ , find  $\mathbf{H}$  in each region.

**Soln:** We know that, the normal components are related as

$$\mu_0\mu_{r1}\mathbf{H}_1 = \mu_0\mu_{r2}\mathbf{H}_2 = \mu_0\mu_{r3}\mathbf{H}_3$$

Hence,

$$\mathbf{H}_1 = \frac{\mathbf{B}_1}{\mu_0\mu_{r1}} = \frac{0.2}{\mu_0} = \mu_0\mu_{r2}\mathbf{H}_2$$

$$\Rightarrow \mathbf{H}_2 = \frac{0.2}{500\mu_0} = 0.04 \times 10^{-2} = \frac{4 \times 10^{-4}}{\mu_0} \text{ A/m}$$

and the corresponding magnetic field in region 3 is

$$\mu_0\mu_{r1}\mathbf{H}_1 = \mu_0\mu_{r3}\mathbf{H}_3 \Rightarrow \mathbf{H}_1 = \mathbf{H}_3 = \frac{0.2}{\mu_0} \text{ A/m}$$

**Ex 1.11.** Obtain the unit vector along the direction of propagation of a wave, the displacement of which is given by  $\Psi(x, y, z, t) = a \cos(2x + 3y + 4z - 5t)$ .

**Soln:** The unit vector along the direction of propagation of the wave is corresponding to the plane  $2x + 3y + 4z = \text{constant}$

Hence, it becomes

$$\frac{2}{\sqrt{2^2 + 3^2 + 4^2}} \hat{\mathbf{x}} + \frac{3}{\sqrt{2^2 + 3^2 + 4^2}} \hat{\mathbf{y}} + \frac{4}{\sqrt{2^2 + 3^2 + 4^2}} \hat{\mathbf{z}}$$

$$= \frac{2}{\sqrt{29}} \hat{\mathbf{x}} + \frac{3}{\sqrt{29}} \hat{\mathbf{y}} + \frac{4}{\sqrt{29}} \hat{\mathbf{z}}$$

**Ex 1.12.** The displacement associated with a three-dimensional wave is given by

$$\Psi(x, y, z, t) = a \cos\left(\frac{\sqrt{3}}{2}kx + \frac{1}{2}ky - \omega t\right). \text{ Find the direction of wave propagation.}$$

**Soln:** The generalized wave equation is

$$\Psi(\mathbf{r}, t) = \text{Re}\{E_0 \exp(\mathbf{k} \cdot \mathbf{r} - \omega t)\}$$

For the given problem, the two components of the vector  $\mathbf{k}$  are

$k_x = k_y = k$  and the two components of the position vector are

$$r_x = \cos^{-1}\left(\frac{\sqrt{3}}{2}\right) = 30^\circ$$

$$r_y = \cos^{-1}\left(\frac{1}{2}\right) = 60^\circ$$

The wave propagates in the  $xy$  – plane making an angle of  $30^\circ$  with the positive  $x$  – axis and  $60^\circ$  with the positive  $y$  – axis.

**Ex 1.13** Find the force per unit area on the surface of a conductor, with surface charge density  $\sigma$  in the presence of an electric field ( $\mathbf{a}_n$ ) is the unit outward normal to the surface.

**Soln:** The electric field at a given point due to the surface charge density is

$$\mathbf{E} = \frac{\sigma}{2\epsilon_0} \mathbf{a}_n$$

Force per unit area due to another sheet charge is

$$\mathbf{F} = E \cdot q = \frac{\sigma}{2\epsilon_0} \cdot \sigma \mathbf{a}_n = \frac{\sigma^2}{2\epsilon_0} \mathbf{a}_n$$

**Ex 1.14** Inside a right circular cylinder,  $\mu_{r1} = 1000$ . The exterior is free space. If  $\mathbf{B}_1 = 2.5\hat{\phi}$  (T) inside the cylinder, determine  $\mathbf{B}_2$  just outside.

**Soln:** We know that the tangential component of  $\mathbf{H}$  is continuous across the boundary.

Thus,

$$\frac{\mathbf{B}_1}{\mu_0 \mu_{r1}} = \frac{\mathbf{B}_2}{\mu_0 \mu_{r2}} \text{ and hence, } \mathbf{B}_2 = \frac{2.5}{1000} \hat{\phi} \text{ mT}$$

**Ex 1.15.** In free space,  $\mathbf{B} = B_m e^{j(\omega t + \beta z)} \hat{\mathbf{y}}$ . Find the corresponding electric field.

**Soln:** We know that

$$\nabla \times \mathbf{H} = \varepsilon_0 \frac{\partial \mathbf{E}}{\partial t} = \nabla \times \frac{\mathbf{B}}{\mu_0} = \varepsilon_0 \frac{\partial \mathbf{E}}{\partial t} \Rightarrow \nabla \times \mathbf{B} = \mu_0 \varepsilon_0 \frac{\partial \mathbf{E}}{\partial t} = j\omega\mu_0\varepsilon_0 \mathbf{E}$$

If we expand the above expression we get

$$\begin{bmatrix} \hat{\mathbf{x}} & \hat{\mathbf{y}} & \hat{\mathbf{z}} \\ \frac{\partial}{\partial x} & \frac{\partial}{\partial y} & \frac{\partial}{\partial z} \\ B_x & B_y & B_z \end{bmatrix} = \left( \frac{\partial B_z}{\partial y} - \frac{\partial B_y}{\partial z} \right) \hat{\mathbf{x}} - \left( \frac{\partial B_z}{\partial x} - \frac{\partial B_x}{\partial z} \right) \hat{\mathbf{y}} + \left( \frac{\partial B_y}{\partial x} - \frac{\partial B_x}{\partial y} \right) \hat{\mathbf{z}} = j\omega\mu_0\varepsilon_0 \mathbf{E}$$

In the above expression we understand that the magnetic field has an  $y$  component only

and further  $\frac{\partial}{\partial x} = 0 = \frac{\partial}{\partial y}$ ,  $\frac{\partial}{\partial z} = j\beta$ . Therefore,

$$\frac{\partial B_y}{\partial z} = j\beta B_m e^{j(\omega t + \beta z)}$$

$$\text{and } \mathbf{E} = -\frac{j\beta B_m}{j\omega\mu_0\varepsilon_0} e^{j(\omega t + \beta z)} \hat{\mathbf{x}} = -\frac{\beta B_m}{\omega\mu_0\varepsilon_0} e^{j(\omega t + \beta z)} \hat{\mathbf{x}}$$

$$\text{As } \frac{1}{\mu_0\varepsilon_0} = \frac{\omega^2}{\beta^2} \Rightarrow \mu_0\varepsilon_0 = \frac{\beta^2}{\omega^2}$$

Substitution of the above in the electric field expression we get

$$\mathbf{E} = -\frac{\beta B_m}{\omega\mu_0\varepsilon_0} e^{j(\omega t + \beta z)} \hat{\mathbf{x}} = -\frac{\beta B_m}{\omega(\beta^2/\omega^2)} e^{j(\omega t + \beta z)} \hat{\mathbf{x}} = -\frac{\omega B_m}{\beta} e^{j(\omega t + \beta z)} \hat{\mathbf{x}}$$

This expression shows that the electric field  $\mathbf{E}$  and the magnetic field  $\mathbf{H}$  are in space quadrature but in time phase. Both of the fields propagate with the same velocity in the positive  $z$  direction.

**Ex.1.16** Find the electric field in the region between the two cones as shown in Fig.1.1.

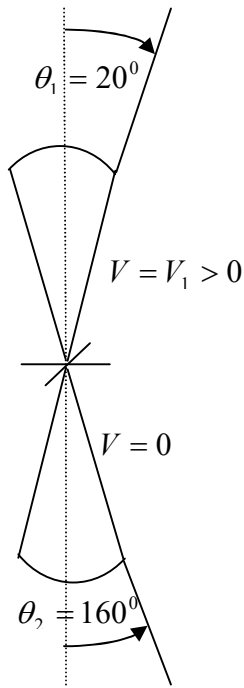

Fig.1.1 Figure for Ex.1.16

**Soln:** The potential is observed to be a function of the azimuthal angle  $\theta$  only and is a constant with respect to  $r$  and  $\phi$ . Hence, Laplace's equation becomes

$$\frac{1}{r^2 \sin \theta} \frac{d}{d\theta} \left( \sin \theta \frac{dV}{d\theta} \right) = 0$$

$$\frac{d}{d\theta} \left( \sin \theta \frac{dV}{d\theta} \right) = 0$$

$$\Rightarrow \sin \theta \frac{dV}{d\theta} = K$$

$$\Rightarrow \frac{dV}{d\theta} = K \csc \theta$$

$$\Rightarrow V = K \ln(\csc \theta - \cot \theta) + C$$

$$\text{The term } \csc \theta - \cot \theta = \frac{1}{\sin \theta} - \frac{\cos \theta}{\sin \theta} = \frac{1 - \cos \theta}{\sin \theta} = \frac{2 \sin^2(\theta/2)}{2 \sin(\theta/2) \cdot \cos(\theta/2)} = \tan(\theta/2)$$



$$\frac{dV}{d\theta} = K \csc \theta$$

$$\Rightarrow V = -K \ln |\csc \theta + \cot \theta| = -K \ln \left| \frac{1}{\sin \theta} + \frac{\cos \theta}{\sin \theta} \right|$$

$$= -K \ln \left| \frac{1 + \cos \theta}{\sin \theta} \right| = -\ln \left| \frac{2 \cos^2 \left( \frac{\theta}{2} \right)}{2 \sin \left( \frac{\theta}{2} \right) \cdot \cos \left( \frac{\theta}{2} \right)} \right| = \ln \cot \left( \frac{\theta}{2} \right) + C$$

$$\mathbf{E} = -\nabla V = -\frac{1}{r} \frac{\partial V}{\partial \theta} \mathbf{a}_\theta = -\frac{1}{r} \frac{\partial}{\partial \theta} \left[ K \ln \cot \left( \frac{\theta}{2} \right) + C \right] \mathbf{a}_\theta$$

$$\frac{1}{r} \frac{\partial V}{\partial \theta} = -\frac{K}{2r} \tan \left( \frac{\theta}{2} \right) \csc^2 \left( \frac{\theta}{2} \right) = -\frac{K}{2r} \frac{\sin \left( \frac{\theta}{2} \right)}{\cos \left( \frac{\theta}{2} \right)} \cdot \frac{1}{\sin^2 \left( \frac{\theta}{2} \right)}$$

$$\mathbf{E} = \frac{K}{r \sin \theta} \mathbf{a}_\theta$$

The potential between the two cones equidistant from the origin is therefore

$$V = - \int_{\theta_1}^{\pi - \theta_1} \mathbf{E} \cdot d\mathbf{l} = - \int_{\theta_1}^{\pi - \theta_1} \frac{K}{r \sin \theta} \cdot r d\theta$$

$$= -K \int_{\theta_1}^{\pi - \theta_1} \frac{K}{\sin \theta} \cdot d\theta$$

$$= K \ln \cot \left( \frac{\theta}{2} \right)$$

Therefore, the solution to the potential becomes

$$V = K \ln(\csc \theta - \cot \theta) + C$$

$$= K \ln \left[ \tan \left( \frac{\theta}{2} \right) \right] + C$$

Further, we observe that,  $V = V_1$  at  $\theta = \theta_1$  and  $V = 0$  at  $\theta = \theta_2$ . Therefore,

$$V_1 = K \ln \left[ \tan \left( \frac{\theta_1}{2} \right) \right] + C \text{ and}$$

$$0 = K \ln \left[ \tan \left( \frac{\theta_2}{2} \right) \right] + C$$

$$\Rightarrow C = -K \ln \left[ \tan \left( \frac{\theta_2}{2} \right) \right]$$

From these two, we obtain

$$V_1 = K \ln \left[ \tan \left( \frac{\theta_1}{2} \right) \right] - K \ln \left[ \tan \left( \frac{\theta_2}{2} \right) \right]$$

$$\Rightarrow K = \frac{V_1}{\ln \left[ \tan \left( \frac{\theta_1}{2} \right) \right] - \ln \left[ \tan \left( \frac{\theta_2}{2} \right) \right]}$$

The potential is, therefore

$$V = V_1 \frac{\ln \left[ \tan \left( \frac{\theta}{2} \right) \right] - \ln \left[ \tan \left( \frac{\theta_2}{2} \right) \right]}{\ln \left[ \tan \left( \frac{\theta_1}{2} \right) \right] - \ln \left[ \tan \left( \frac{\theta_2}{2} \right) \right]}$$

The electric field is evaluated as

$$\mathbf{E} = -\nabla V = -\frac{1}{r} \frac{\partial V}{\partial \theta} \mathbf{a}_\theta = -\frac{1}{r} \frac{\partial}{\partial \theta} \left\{ \left[ K \ln \tan \left( \frac{\theta}{2} \right) + C \right] \right\} \mathbf{a}_\theta$$

$$\frac{1}{r} \frac{\partial V}{\partial \theta} = \frac{K}{2r} \cot \left( \frac{\theta}{2} \right) \sec^2 \left( \frac{\theta}{2} \right) = \frac{K}{2r} \frac{\cos \left( \frac{\theta}{2} \right)}{\sin \left( \frac{\theta}{2} \right)} \cdot \frac{1}{\cos^2 \left( \frac{\theta}{2} \right)}$$

$$= \frac{K}{r \sin \theta} = \frac{V_1}{\ln \left[ \tan \left( \frac{\theta_1}{2} \right) \right] - \ln \left[ \tan \left( \frac{\theta_2}{2} \right) \right] r \sin \theta} = \frac{V_1}{\ln(\tan 10^\circ) - \ln(\tan 80^\circ) r \sin \theta}$$

$$\mathbf{E} = \frac{0.288}{r \sin \theta} V_1 \mathbf{a}_\theta$$

The general electric field is evaluated as

$$\mathbf{E} = -\nabla V = -\frac{1}{r} \frac{\partial V}{\partial \theta} \mathbf{a}_\theta = -\frac{1}{r} \left[ K \ln \tan \left( \frac{\theta}{2} \right) + C \right] \mathbf{a}_\theta$$

$$= -\frac{K}{2r} \cot \left( \frac{\theta}{2} \right) \sec^2 \left( \frac{\theta}{2} \right) \mathbf{a}_\theta = -\frac{K}{2r} \frac{\cos \left( \frac{\theta}{2} \right)}{\sin \left( \frac{\theta}{2} \right)} \cdot \frac{1}{\cos^2 \left( \frac{\theta}{2} \right)} \mathbf{a}_\theta$$

$$= -\frac{K}{r \sin \theta} \mathbf{a}_\theta$$

Hence, the total electric flux bounded by the conical surface is

$$D = \iint_S \varepsilon \mathbf{E} \cdot d\mathbf{s} = \varepsilon \int_0^R \int_0^\pi \frac{K}{r \sin \theta} \cdot r \sin \theta d\phi dr$$

$$= \pi \varepsilon K R = Q$$

The total charge enclosed by the surface. Therefore, the capacitance per unit length is given as

$$C = \frac{Q}{V} = \frac{\pi\epsilon K}{K \ln \left[ \cot \left( \frac{\theta}{2} \right) \right]} = \frac{\pi\epsilon}{\ln \left[ \cot \left( \frac{\theta}{2} \right) \right]}$$

The integral of  $\csc x$  is  $-\ln|\csc x + \cot x|$

In spherical coordinates, under the assumption that the potential at a given point is a function of the radial distance from the source, then we have

$$\nabla^2 V = \frac{1}{r^2} \frac{\partial}{\partial r} \left( r^2 \frac{\partial V}{\partial r} \right) = 0$$

$$\Rightarrow \left( r^2 \frac{\partial V}{\partial r} \right) = K$$

$$\Rightarrow \frac{\partial V}{\partial r} = \frac{K}{r^2}$$

$$\Rightarrow V = -\frac{K}{r} + C$$

The two most important theorems often used to evaluate radiated fields due to various conductor configurations are Gauss's divergence theorem and Stoke's theorem. The former as the name suggests is related to the divergence of a vector and the latter is related to the curl of a vector. The divergence theorem states that

$$\oint_S \mathbf{D} \cdot d\mathbf{s} = \iiint_V \rho dv = \iiint_V \nabla \cdot \mathbf{D} dv$$

This gives us

$$\nabla \cdot \mathbf{D} = \rho$$

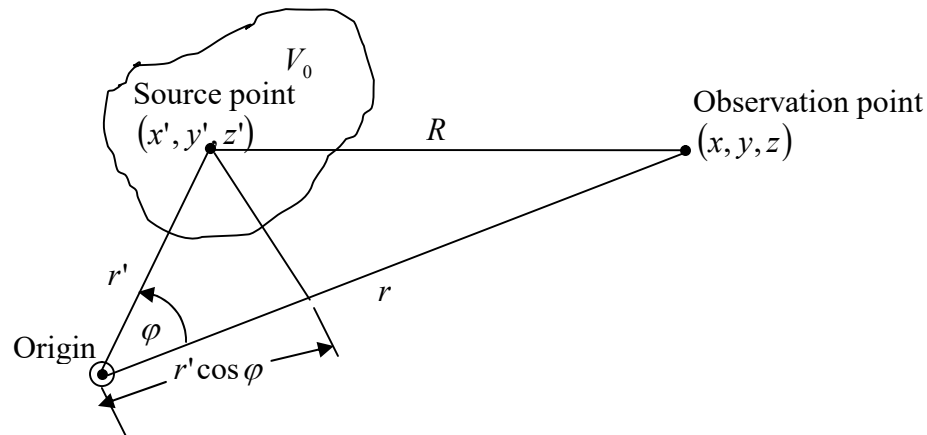

Fig.1.2 Path difference between a source point and an observation point

The potential  $V$  due to a continuous charge distribution  $\rho$  contained in the volume  $V_0$  is expressed as

$$V(r) = \frac{1}{4\pi\epsilon} \iiint_{V_0} \frac{\rho(\mathbf{r}')}{R} dv' \quad (\text{B})$$

where  $dv' = dx' dy' dz'$ . The distance  $R$  is computed as follows:

$$\begin{aligned} R^2 &= [(x-x')^2 + (y-y')^2 + (z-z')^2] \\ &= [(r-r'\cos\varphi)^2 + (r'\sin\varphi)^2] \\ &= (r^2 - 2rr'\cos\varphi + r'^2\cos^2\varphi + r'^2\sin^2\varphi) \quad (\text{c}) \\ &= (r^2 - 2rr'\cos\varphi + r'^2) \\ &= r^2 \left( 1 - 2\frac{r'}{r}\cos\varphi + \frac{r'^2}{r^2} \right) \end{aligned}$$

We can simplify the distance by writing

$$\begin{aligned} R^{-1} &= (r^2 - 2rr'\cos\varphi + r'^2)^{-\frac{1}{2}} \\ &= r^{-1} \left( 1 - 2\frac{r'}{r}\cos\varphi + \frac{r'^2}{r^2} \right)^{-\frac{1}{2}} \\ &= r^{-1} \left[ 1 + 2\frac{r'}{r}\cos\varphi + \frac{1}{2}(3\cos^2\varphi - 1)\left(\frac{r'}{r}\right)^2 + \dots \right] \quad (\text{D}) \\ &= r^{-1} \sum_{m=0}^{\infty} P_m \left( \frac{r'}{r} \right)^m \cos\varphi \end{aligned}$$

We note that the term  $r'\cos\varphi$  also represents the projection of  $r'$  onto  $r$  and therefore, can be expressed as  $\mathbf{r}' \cdot \mathbf{a}_r$ .

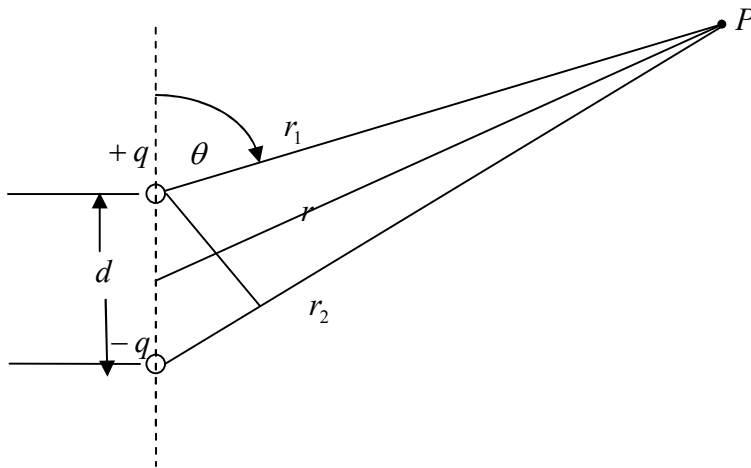

Fig.1.3 An electric dipole that makes use of the principle outlined in Fig.1.2 (An infinitesimal electric dipole)

Two approximations are usually carried out for the far field of the antennas. These are made to the amplitude and phase of the radiated fields. The approximations are:

$R \approx r - r' \cos \varphi$  for the phase term and  
 $R \approx r$  for the amplitude term

The charge dipole, hence may be expressed as

$$\rho(\mathbf{r}) = q\delta(x)\delta(y)\left[\delta\left(z - \frac{d}{2}\right) - \delta\left(z + \frac{d}{2}\right)\right]$$

The far field potential as obtained from (D) may be expressed as

$$\begin{aligned} 4\pi\epsilon V(\mathbf{r}) &= \frac{1}{r^2} \iiint_V \rho(\mathbf{r}')(\mathbf{r}' \cdot \mathbf{a}_r) dv \\ &= \frac{1}{r^2} \iiint_V q\delta(x)\delta(y)\left[\delta\left(z - \frac{d}{2}\right) - \delta\left(z + \frac{d}{2}\right)\right] z' \cos \theta dx' dy' dz' \\ &= \frac{qd \cos \theta}{r^2} \end{aligned}$$

This is due to the fact that  $\int \delta(x) dx = 1$  and

$$\begin{aligned} &\int \left[\delta\left(z - \frac{d}{2}\right) - \delta\left(z + \frac{d}{2}\right)\right] dz \\ &= \frac{d}{2} - \left(-\frac{d}{2}\right) = d \end{aligned}$$

This follows from the fact that the delta function  $\delta(x)$  assumes a value of unity only at  $x = 0$  and is zero at all other values of  $x$ . Further, the area bounded by a dirac delta function is equal to one.

$$\int_{-\infty}^{\infty} \delta(x) dx = 1$$

This result due to an electric dipole consisting of two fixed static charges gives us the potential at a faraway point. We may observe that the negative of the gradient of the potential gives us the electric field evaluated as

$$\mathbf{E} = -\nabla V$$

$$\Rightarrow E_r = -\frac{\delta V}{\delta r} a_r = -\frac{2qd \cos \theta}{4\pi\epsilon r^3}$$

$$E_\theta = -\frac{\delta V}{r \delta \theta} = \frac{qd}{4\pi\epsilon r^3} \sin \theta$$

$$\text{and } E_\phi = -\frac{\delta V}{r \sin \theta \delta \phi} = 0$$

These fields are static and they are constants both in magnitude as well as in direction at a certain distance  $r$  from the source. They also vary inversely as the cube of the distance which means that at really far distances from the source, their magnitude becomes too insignificant to carry energy or power. These cannot act as radiated fields as required in a power transfer by wireless methods. We must have a field that varies at most as the inverse of the squared distance from the source. Moreover, the field needs to be time varying so that we get radiated fields. Also a magnetic field is required to carry energy

from one point to another in a wireless manner. We take up the generation of the electromagnetic fields first to understand this wireless transfer of energy by electric and associated magnetic fields generated due to time varying sources.

Stoke's law as related to the curl of a vector states that

$$\oint_s (\nabla \times \mathbf{H}) \cdot d\mathbf{s} = \oint \mathbf{H} \cdot d\mathbf{s}$$

The standard wave equations are

$$\nabla^2 \mathbf{A} - \mu\epsilon \frac{\partial^2 \mathbf{A}}{\partial t^2} = -\mu\mathbf{J} \quad \text{and} \quad \nabla^2 V - \mu\epsilon \frac{\partial^2 V}{\partial t^2} = -\frac{\rho}{\epsilon}$$

Under the assumption of sinusoidal steady state, the wave equations become

$$\nabla^2 \mathbf{A} + \mu\epsilon\omega^2 \mathbf{A} = -\mu\mathbf{J}$$

$$\nabla^2 V + \omega^2 \mu\epsilon V = -\frac{\rho}{\epsilon}$$

The magnetic vector potential  $\mathbf{A}$  at a given observation point far away from a current source similarly can be evaluated with the aid of Fig. (A) except that the charge as a source should be replaced by a current source that has a current density of  $J \text{ A/m}^2$  established and therefore, we can similarly write

$$\mathbf{A}(r) = \frac{1}{4\pi} \iiint_{V_0} \frac{\mu\mathbf{J}(\mathbf{r}')}{R} dv'$$

As we may observe, the distance of the observation point from the source  $R$  is given by (B) .

### Transmission Lines

The transit time effect is an important issue in the characterization of high frequency behavior of electric circuits. At low frequencies, the wavelength is long and the time period of a given signal is also long. This means that, if a source in the form of a periodic waveform is present at one particular point of the circuit at a given point in time, it would be available on some different point almost at the same time.

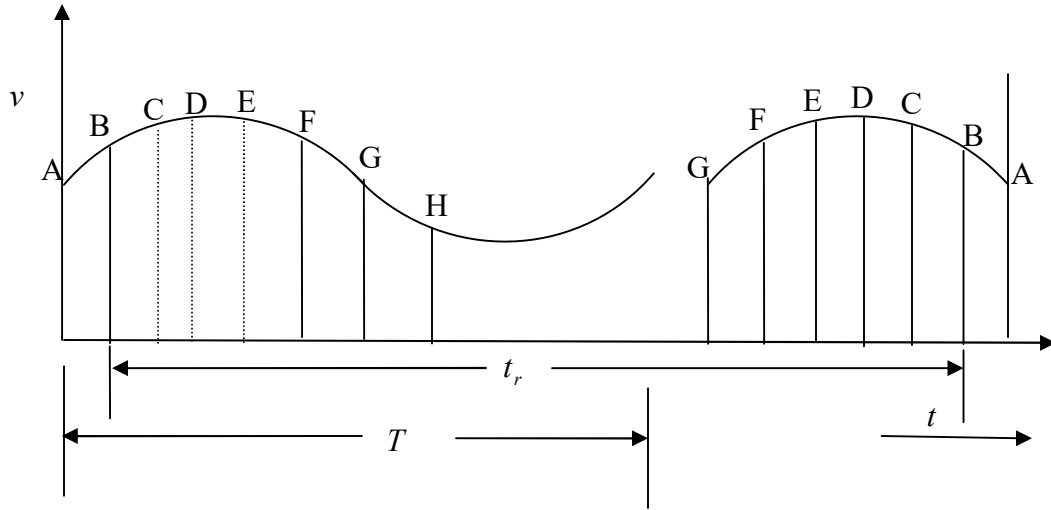

We observe that, the points marked A-G require a finite amount of time  $t_r$  to reach the destination end, also known as the load. This is known as the retrace time. The time period of the signal is  $T$ . We may see that, these two times are almost comparable. By the time point A reaches the destination, the source signal changes to a point marked load end. As the voltage goes to different values between the source and the load end, which are some distance apart, we get a phase difference between these two points. A similar situation holds good for all other points. This is due to the fact that the time to reach the load and the time period of the source are comparable. If we increase the frequency of the source, we may anticipate that the phase change would be more. To describe it mathematically, we define the electrical length of the circuit as  $L/\lambda$  where  $L$  is the physical length between the source and the load and  $\lambda$  is the wavelength of the signal (voltage or current) impressed at the source end. The quasi-static regime is defined for  $L/\lambda \ll 1$  which is typical of low frequency lumped circuit parameters. As we may see, the wavelength of the signal is much longer than the physical distance between the source and the load. Let us define the transit time as  $t_r = L/v$ . Hence, in this case,

$$t_r = L/v = \frac{L}{\lambda f} = \frac{L}{\lambda} \cdot T$$

$$\Rightarrow \frac{t_r}{T} = \frac{L}{\lambda} \ll 1$$

This simply means that the signal impressed at the source end reaches the load in a very small amount of time. In other words, the transit time is such that, during this time, the signal at the source end does not change much as it has a longer time period as compared to the transit time.

However, as the frequency of the source increases, the time period gets correspondingly shorter and by the time one particular point of the source signal reaches the load end, the source signal changes to a different value, The signal amplitudes are at different values between the source and the load end and this gives rise to the resonance region

characterized by  $\frac{t_r}{T} = \frac{L}{\lambda} \sim 1$ . The transit time becomes an appreciable fraction of the time period which means that the source and the load ends experience different amplitudes of the signal which gives rise to a phase difference between them and it becomes a function of the physical distance or the electrical length of the circuit. Due to the phase difference between two different points of the circuit (observed at the same time of course), the effect is a distribution of frequency sensitive elements like inductance and capacitance over the length of the circuit. As practical circuits exhibit losses, there are resistances and conductances as well distributed throughout the length of the circuit. This gives rise to the so called distributed circuit analysis.

$$\Delta V = -(R\Delta x + j\omega L\Delta x)I$$

$$\Delta I = -(G\Delta x + j\omega C\Delta x)V$$

These equations can be written as

$$\frac{\Delta V}{\Delta x} = -(R + j\omega L)I \quad \text{and} \quad \frac{\Delta I}{\Delta x} = -(G + j\omega C)V$$

For the lumped circuit analysis to hold good,  $\Delta x \rightarrow 0$ . Doing so, we get

$$\lim_{\Delta x \rightarrow 0} \frac{\Delta V}{\Delta x} = \frac{dV}{dx} = -(R + j\omega L)I \quad \text{and similarly,}$$

$$\lim_{\Delta x \rightarrow 0} \frac{\Delta I}{\Delta x} = \frac{dI}{dx} = -(G + j\omega C)V$$

The voltage and the currents on a transmission line are governed by two coupled first order differential equations as given above. To solve those, let us differentiate both w.r.t.  $x$  so that we have

$$\frac{d^2 V}{dx^2} = -(R + j\omega L)\frac{dI}{dx} \quad \text{and} \quad \frac{d^2 I}{dx^2} = -(G + j\omega C)\frac{dV}{dx}$$

Substituting the expressions for the first order differentials in these,

$$\frac{d^2 V}{dx^2} = (R + j\omega L)(G + j\omega C)V$$

$$\frac{d^2 I}{dx^2} = (R + j\omega L)(G + j\omega C)I$$

Let us write

$$\gamma^2 = (R + j\omega L)(G + j\omega C)$$

So that, now the two equations become

$$\frac{d^2 V}{dx^2} = \gamma^2 V$$

and

$$\frac{d^2 I}{dx^2} = \gamma^2 I$$



Both the equations are governed by the same second order differential equations. As we might see, the constant  $\gamma$  is a constant at a given frequency. The solutions to the voltage and current along the line are:

$$V = V^+ \exp(-\gamma x) + V^- \exp(\gamma x)$$

$$I = I^+ \exp(-\gamma x) + I^- \exp(\gamma x)$$

The  $V^+, V^-, I^+, I^-$  are arbitrary constants that are to be evaluated by appropriate boundary conditions. These constants are in general complex and their phases represent temporal phases with respect to some reference time. As we may see, in these expressions, the time harmonic function is implicit. The total solution, is therefore,

$$V = [V^+ \exp(-\gamma x) + V^- \exp(\gamma x)] \exp(j\omega t)$$

$$I = [I^+ \exp(-\gamma x) + I^- \exp(\gamma x)] \exp(j\omega t)$$

From these two expressions we see that, they represent a standing wave on the line; one goes along the positive  $x$ -axis given by  $\exp(-\gamma x)$  with an amplitude of  $V^+$  and the other along the negative  $x$ -axis given by  $\exp(\gamma x)$  having a amplitude of  $V^-$ . A similar condition holds for the current flowing in the line. What we see is that instead of talking about voltage and current at a given point on the line, now we have two waves in two opposite directions with two different peak amplitudes. The most important observation is that, both voltage and current are functions of the given point in space;  $x$  – axis. This is unlike the low frequency characterization of voltage and current where both are functions of time only. They are temporal functions. However, for the transmission lines, the voltage and currents are also spatial functions. Therefore, we may guess that, the impedance is also point specific; it is a function of space.

Let us write

$$\gamma = \alpha + j\beta$$

The constant  $\alpha$  is known as the attenuation constant of the line; as it attenuates the wave as it propagates along the line. The unit of  $\alpha$  is neper/m. This means that if the voltage travels a length of 1 m from the source, it decays to a value of  $e^{-1}$  of its amplitude at the source. The attenuation, in dB is, therefore,  $20 \log(e^{-1}) = -8.68$  dB.

To evaluate the four constants, we proceed as

$$-\gamma V^+ \exp(-\gamma x) + \gamma V^- \exp(\gamma x) = -(R + j\omega L) [I^+ \exp(-\gamma x) + I^- \exp(\gamma x)]$$

Equating respective terms on both sides, we have, for the coefficient of  $\exp(-\gamma x)$

$$\gamma V^+ = (R + j\omega L) I^+ \text{ and similarly, for the coefficient of } \exp(\gamma x)$$

$$-\gamma V^- = -(R + j\omega L) I^-$$

$$\frac{V^+}{I^+} = \frac{(R + j\omega L)}{\gamma} = \frac{(R + j\omega L)}{\sqrt{(R + j\omega L)(G + j\omega C)}} = \sqrt{\frac{R + j\omega L}{G + j\omega C}} \text{ and}$$

$$\frac{V^-}{I^-} = -\frac{(R + j\omega L)}{\gamma} = -\sqrt{\frac{R + j\omega L}{G + j\omega C}}$$

The quantity  $\sqrt{\frac{R + j\omega L}{G + j\omega C}}$  has the dimensions of impedance denoted as

$$Z_0 = \sqrt{\frac{R + j\omega L}{G + j\omega C}}$$

This  $Z_0$  is known as the characteristic impedance. The parameters  $\gamma$  and  $Z_0$  are known as the secondary parameters of the transmission line.

## MODULE-II

### 2. GENERATION OF ELECTROMAGNETIC WAVES

An antenna is a structure usually made from a good conducting material that has been designed to have a shape and size such that it will radiate EM power in an efficient manner. Time-varying currents radiate EM waves. Thus an antenna is a structure on which time-varying currents can be excited with a relatively large amplitude when the antenna is connected to a suitable source usually by means of a transmission line or waveguide. In order to radiate efficiently, the minimum size of the antenna must be comparable to the wavelength. A generic structure for the generation of the EM waves is shown in Fig.2.1.

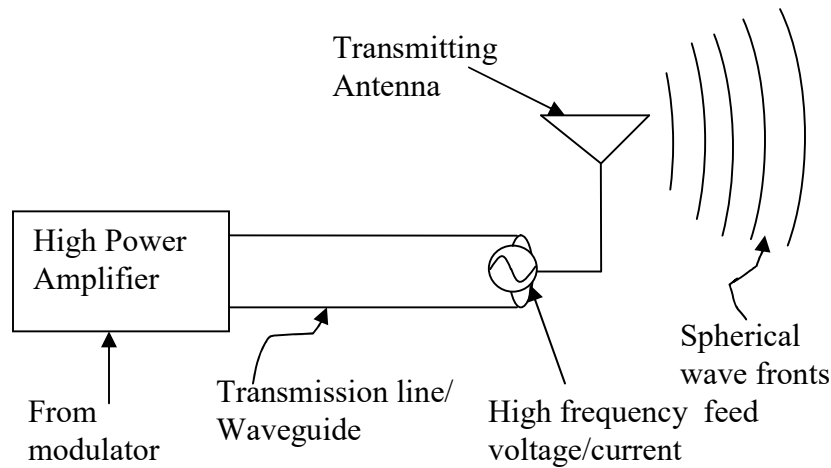

Fig.2.1 A Generic Block Diagram of generation of EM waves through low frequency to high frequency conversion

At frequencies above 40MHz, communication is essentially limited to line-of-sight paths. A typical LOS link is that used for TV broadcasting. Another example is the LOS microwave link used in the telephone service. In order for an antenna to radiate into a small angular region and thereby provide a higher concentration of power at the receiving site, it must be physically large in terms of wavelength. In the microwave band where the wavelength is in the range of 3 to 30 cm, large reflector antennas with gains as large as 40 to 50dB are quite common. With a large available gain, the transmitter power can be reduced accordingly. It is not unusual to use transmitter powers of a few watts or even as

low as a few milliwatts in the microwave band. There is also less atmospheric noise at the higher frequencies so smaller signal levels can be used.

The waveguide is a structure that guides electromagnetic waves from a source to a destination. They transport electromagnetic energy over long distances with a minimum amount of signal loss. The waveguides basically are of two types: metal based and dielectric based. The frequency range of operation of the metallic waveguides range from a few tens of kHz to a few tens of GHz. Beyond these frequencies, these waveguides have excessive losses and become inefficient in the transportation of energy. Dielectric waveguides, on the other hand, beyond millimeter wavelength operation, are used to transport electromagnetic energy, however, in the form of optical signals or light waves. We have either slab or cylindrical waveguides. The slab waveguides are used in thin film applications and integrated optical devices. The optical fibers are cylindrical waveguides that have been widely used in both communication and instrumentation applications due to a number of advantages. The interested reader can refer to standard texts on optical fiber based systems for an in depth knowledge about the working and applications of the optical fibers.

### 2.1 Vector Potential approach in forming a field expression

The vector potential set up by the infinitesimal current element at a distance  $r$  from the origin of the coordinates system under consideration is

$$A(P) = \frac{\mu e^{-j\beta r}}{4\pi r} (Idl)a_z \quad (2.1)$$

We may observe from (2.1) that  $\beta$  represents the wave number given as  $\beta = \frac{2\pi}{\lambda}$ .

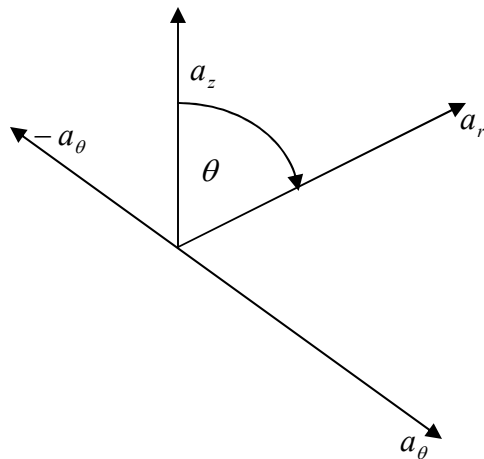

Fig.2.2 Relationship between the unit vectors  $a_r, a_z$  and  $a_\theta$

$$\text{From Fig.2.1, in spherical coordinates, } a_z = a_r \cos \theta - a_\theta \sin \theta \quad (2.2)$$

Substitution of (2.2) in (2.1) we have,

$$A(P) = \frac{\mu e^{-j\beta r}}{4\pi r} (Idl) [a_r \cos \theta - a_\theta \sin \theta] \quad (2.3)$$

the vector magnetic potential as defined above gives a corresponding magnetic field in the region outside of the current source as

$$H = \frac{1}{\mu} \Delta \times A \quad (2.4)$$

$$\text{which gives the } (\Delta \times A)_\phi = \frac{1}{r} \left[ \frac{\partial}{\partial r} (rA_\theta) - \frac{\partial A_r}{\partial \theta} \right] \quad (2.5)$$

The validity of (2.5) follows from the fact that a current flowing through a conductor along the positive  $z$  – axis produces a magnetic field in the form of loops contained in the  $xy$  – plane and has a  $\phi$  component only. We, therefore have, from elementary magnetostatics,

$$H_\phi = \frac{I}{2\pi r} a_\phi \quad (2.6)$$

From (2.3), we note that,

$$A_\theta = -\frac{\mu e^{-j\beta r}}{4\pi r} (Idl) \sin \theta a_\theta \quad \text{and} \quad (2.7a)$$

$$A_r = \frac{\mu e^{-j\beta r}}{4\pi r} (Idl) \cos \theta \quad (2.7b)$$

$$\text{Further, } rA_\theta = -\frac{\mu e^{-j\beta r}}{4\pi} (Idl) \sin \theta a_\theta \quad (2.8)$$

$$\text{Thus, } \frac{\partial}{\partial r} (rA_\theta) = \frac{\mu j \beta e^{-j\beta r}}{4\pi} (Idl) \sin \theta a_\theta \quad (2.9a)$$

$$\text{and } -\frac{\partial}{\partial \theta} (A_r) = \frac{\mu e^{-j\beta r}}{4\pi r} (Idl) \sin \theta \quad (2.9b)$$

Use of (2.9) gives (2.5) as

$$(\Delta \times A)_\phi = \frac{1}{r} \left[ \frac{\mu j \beta e^{-j\beta r}}{4\pi} (Idl) \sin \theta + \frac{\mu e^{-j\beta r}}{4\pi r} (Idl) \sin \theta \right] = \mu \frac{Idl}{4\pi} \beta^2 \sin \theta e^{-j\beta r} \left[ \frac{j}{\beta r} + \frac{1}{\beta^2 r^2} \right] \quad (2.10)$$

If current flows through the positive- $z$  direction, we note that,

$$A_\theta = \cos \theta \cos \phi a_x + \cos \theta \sin \phi a_y - \sin \theta a_z \quad (2.11)$$

Under the assumption that  $\frac{\partial}{\partial \phi} = 0$ , we write (2.11) as

$$A_\theta = -\sin \theta a_z \quad (2.12)$$

$$\text{Thus, } (\Delta \times A)_\phi = -\frac{Idl}{r^2} \sin \theta a_\phi$$

$$\text{If } A = \frac{Idl}{4\pi r} a_z, \text{ then } \frac{\partial A_z}{\partial r} = -\frac{Idl}{4\pi r^2} \quad (2.13)$$

This gives us

$$(\Delta \times A)_\phi = -\sin \theta \frac{\partial A_z}{\partial r} \quad (2.14)$$

The result given in (2.14) gives the far field distribution for most of the practical antennas.

The elementary magnetic field due to an elementary current  $Idl$  flowing in the positive  $z$ -direction at a distance  $r$  from the origin is given as

$$dH = \frac{Idl \times a_R}{4\pi R^2} \quad (2.15)$$

As we note from above, for a current in the positive  $z$ -direction, this becomes

$$dH = \frac{Idl \times a_R}{4\pi R^2} = \frac{Idz a_z \times a_R}{4\pi R^2} \quad (2.16)$$

Substitution of (2.2) in (2.16) gives us

$$dH = \frac{Idz a_z \times a_r}{4\pi r^2} = \frac{Idz(a_r \cos \theta - a_\theta \sin \theta) \times a_r}{4\pi r^2} = \frac{Idz(\sin \theta)(-a_\phi)}{4\pi r^2} = \frac{Idl(\sin \theta)a_\phi}{4\pi r^2} \quad (2.17)$$

as for the current flow such as this,  $dz = dl$

(2.17) also gives the noted Biot-Savart law in the spherical coordinate.

For a current element  $Idl$ , the phasor magnetic vector potential, from (2.13) is

$$A_z = \frac{\mu Idl}{4\pi r} e^{-j\beta r} \quad (2.18)$$

Differentiating (2.18) w.r.t.  $r$ , we obtain

$$\frac{\partial A_z}{\partial r} = -j\beta \frac{\mu Idl}{4\pi r} e^{-j\beta r} + \frac{\mu Idl}{4\pi r} e^{-j\beta r} \left( -\frac{1}{r^2} \right) = -\frac{\mu Idl}{4\pi r} e^{-j\beta r} \left( j\beta + \frac{1}{r^2} \right) \quad (2.19)$$

Hence, the magnetic field becomes

$$H_\phi = \frac{\mu Idl}{4\pi r} \sin \theta e^{-j\beta r} \left( j\beta + \frac{1}{r^2} \right) \quad (2.20)$$

We note from (2.20) that, the magnetic field has a  $\phi$  component due to a current flow in the  $z$ -direction. The associated electric field is given as

$$E = \frac{1}{\epsilon} \int \nabla \times H dt \quad (2.21)$$

$$(\nabla \times H)_\phi = \frac{1}{r} \left[ \frac{\partial}{\partial r} (rH_\phi) - \frac{\partial H_r}{\partial \theta} \right] \quad (2.22)$$

From (2.22), we understand that, the electric field has an  $r$  and a  $\theta$  component. The  $r$  component is obtained from the first term in the RHS by taking its curl and subsequent integration of it with respect to time. This becomes then,

$$\begin{aligned} \frac{\partial H_\phi}{\partial r} &= \frac{Idl \sin \theta}{4\pi} \left[ \frac{\omega \sin \omega \left( t - \frac{r}{v} \right)}{r^2 v} + \frac{\omega^2 \cos \omega \left( t - \frac{r}{v} \right)}{rv^2} - 2 \frac{\cos \omega \left( t - \frac{r}{v} \right)}{r^3} + \frac{\omega \sin \omega \left( t - \frac{r}{v} \right)}{r^2 v} \right] \\ &= \frac{Idl \sin \theta}{4\pi} \left[ 2 \frac{\omega \sin \omega \left( t - \frac{r}{v} \right)}{r^2 v} + \frac{\omega^2 \cos \omega \left( t - \frac{r}{v} \right)}{rv^2} - 2 \frac{\cos \omega \left( t - \frac{r}{v} \right)}{r^3} \right] \end{aligned} \quad (2.23)$$

The  $\theta$  component of the electric field is obtained as the time integral of (2.23). Thus,

$$E_\theta = \frac{Idl \sin \theta}{4\pi\epsilon} \int -\frac{\partial H_\phi}{\partial r} dt \quad (2.24)$$

This is

$$E_\theta = \frac{Idl \sin \theta}{4\pi\epsilon} \left[ 2 \frac{\cos \omega \left( t - \frac{r}{v} \right)}{r^2 v} - \frac{\omega \sin \omega \left( t - \frac{r}{v} \right)}{rv^2} + 2 \frac{\sin \omega \left( t - \frac{r}{v} \right)}{\omega r^3} \right] \quad (2.25)$$

$$\text{Let } t - \frac{r}{v} = t' \quad (2.26)$$

Then (2.25) is expressed as

$$H_\phi = \frac{Idl \sin \theta}{4\pi} \left( \frac{-\omega \sin \omega t'}{rv} + \frac{\cos \omega t'}{r^2} \right) \quad (2.27)$$

$$\text{Similarly, } E_r = \frac{1}{\epsilon} \int -\frac{1}{r} \cdot \frac{\partial H_\phi}{\partial \theta} dt = \frac{1}{\epsilon} \int -\frac{1}{r} \cdot \frac{Idl \cos \theta}{4\pi} \left( \frac{-\omega \sin \omega t'}{rv} + \frac{\cos \omega t'}{r^2} \right) dt \quad (2.28)$$

This becomes

$$E_r = \frac{1}{\epsilon} \int -\frac{1}{r} \cdot \frac{Idl \cos \theta}{4\pi\epsilon} \left( \frac{-\omega \sin \omega t'}{rv} + \frac{\cos \omega t'}{r^2} \right) dt = \frac{Idl \cos \theta}{4\pi\epsilon} \left( \frac{\cos \omega t'}{r^2 v} + \frac{\sin \omega t'}{\omega r^3} \right) \quad (2.29)$$

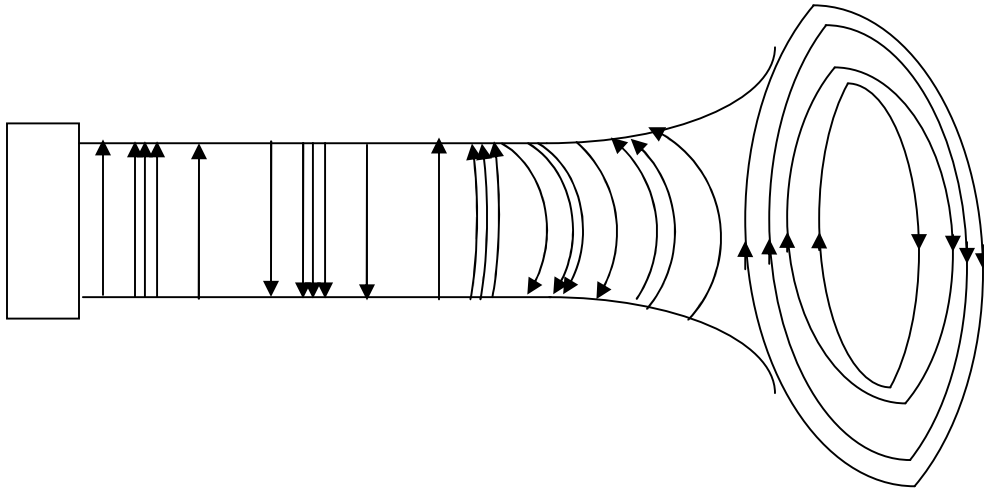

Fig.2.3 Schematic illustration of formation of waves

The electric field lines between two conductors show a pattern similar to that of the voltage source connected across them. For example, if the voltage is sinusoidal, then the lines of force would exhibit a similar sinusoidal pattern in the space between the two conductors and this is illustrated in Fig.2.3. The repetition of the positive and negative half cycles of the electric field take place at a rate equal to the frequency of the applied source. The relative strength of the field is indicated by the closeness or the farness of the lines in Fig.2.1 and the direction is shown by the arrows. An upward going arrow indicates the positive half cycle and a negative going arrow indicates the negative half cycle of the source. The bunching together of the lines at certain points show the occurrence of positive and negative peaks. As the electric field varies in time, it also generates an associated magnetic field as indicated by Maxwell's law. We, therefore, have both electric and magnetic fields inside the space between the two conductors, At the flared end of the conductors, the waves see a change in impedance as a result of which some of them are reflected and travel toward the source. The interference of the forward traveling wave and the reflected wave would produce a standing wave pattern which is not desirable from an antenna point of view. This is simply due to the fact that we would like the antenna or the system of conductors to radiate waves or make possible only a forward flow of energy.

From all the above discussions, we understand that, for a current flow in the positive  $z$  - direction, the magnetic field has a  $\phi$  component whereas the electric field has components both along the  $r$  and the  $\theta$  direction. This implies that, the electric field is contained in the  $r-\theta$  plane which is perpendicular to the magnetic field oriented completely along the  $\phi$  direction. One field gives rise to the other and hence they exist simultaneously. The  $H_\phi$  field as given in (2.20) has two components; i.e. the first term being proportional to inverse of the distance  $r$  from the origin and the second term being proportional to the square of the inverse distance. For small  $r$  close to the current carrying conductor, the second term predominates and this is called induction field. This field is also the magnetic field that would be produced by a current of  $I \cos \omega t$  due to the application of Biot-Savart law except for the factor of  $t'$ . This field is a function of  $t'$  is explained by the fact that, a finite time for propagation is required on the part of the field. This causes an energy that is stored in the field during one quarter of a cycle and returned to the circuit during the next.

The first term is known as radiation or distant field and dominates for large; i.e. at greater distances from the current element. This field is not present for steady currents. This results from the finite time of propagation which is of no concern in the steady-field case. This term is responsible for a flow of energy away from the source. The two fields have equal amplitudes at that value of  $r$  which makes

$$\frac{1}{r^2} = \frac{\omega}{rv} \quad (2.30)$$

$$\text{which implies that, } r = \frac{v}{\omega} = \frac{v}{2\pi f} = \frac{\lambda}{2\pi} \approx \frac{\lambda}{6} \quad (2.31)$$

The amplitudes of the radiation fields of an electric current element  $I dl$  are, from the second term of (2.25)

$$E_{\theta} = \frac{\omega I dl \sin \theta}{4\pi\epsilon v^2 r} = \frac{\eta I dl \sin \theta}{2\lambda r} = \frac{60\pi I dl \sin \theta}{r\lambda} \quad (2.32)$$

The first term of (2.27) gives us the amplitude of the magnetic field as

$$\text{and } H_{\phi} = \frac{\omega I dl \sin \theta}{4\pi v r} = \frac{I dl \sin \theta}{2\lambda r} \quad (2.33)$$

These two relations in (2.32) and (2.33) show that the amplitudes of the electric field and the magnetic field are in time phase but space quadrature. They are related by

$$\frac{E_{\theta}}{H_{\phi}} = \eta \quad (2.34)$$

which is a constant known as the intrinsic impedance of the medium. For example, the intrinsic impedance  $\eta$  corresponding to free space is found to be  $120\pi\Omega$ . Knowing one field will help in computing the other.

From the above it is understood that, a magnetic field is produced only when the current is changing and these two fields exist simultaneously. The two fields are in space quadrature. A static charge produces a steady electric field which does not change with respect to time and hence cannot generate an induced magnetic field. Similarly, a dc current flowing in and around a conductor produces a steady magnetic field that remains constant in magnitude and direction at a given distance from the conductor. This kind of steady magnetic field cannot induce an electric field. We, therefore, see that steady electric and magnetic fields are independent of each other and do not contribute to producing a wave of any kind.

## 2.2 Proof of the outward energy flow due to the radiation term

The instantaneous power flow per unit area at the point P is given by the Poynting vector at that point. The radial Poynting vector is expressed as

$$P_r = E_{\theta} H_{\phi} = \frac{I^2 dl^2 \sin^2 \theta}{16\pi^2 \epsilon} \left( \begin{array}{l} \frac{\sin \omega t' \cos \omega t'}{\omega r^5} + \frac{\cos^2 \omega t'}{r^4 c} - \frac{\omega \sin \omega t' \cos \omega t'}{r^3 c^2} \\ - \frac{\sin^2 \omega t'}{r^4 c} - \frac{\omega \sin \omega t' \cos \omega t'}{r^3 c^2} + \frac{\omega^2 \sin^2 \omega t'}{r^2 c^3} \end{array} \right)$$

$$P_r = \frac{I^2 dl^2 \sin^2 \theta}{16\pi^2 \epsilon} \left( \begin{array}{l} \frac{\sin 2\omega t'}{2\omega r^5} + \frac{\cos 2\omega t'}{r^4 c} - \frac{\omega \sin 2\omega t'}{r^3 c^2} \\ + \frac{\omega^2 (1 - \cos 2\omega t')}{2r^2 c^3} \end{array} \right) \quad (2.35)$$

Hence, the average radial power flow is given by the integral of the instantaneous value over one complete cycle. Doing so, we understand from basic theory that, the first, second, third and the fifth term will yield zero. Hence, we obtain

$$P_{r(av)} = \frac{1}{T} \cdot \frac{I^2 dl^2 \sin^2 \theta}{16\pi^2 \epsilon} \cdot \frac{\omega^2}{2r^2 c^3} \cdot T = \frac{\omega^2 I^2 dl^2 \sin^2 \theta}{32\pi^2 r^2 c^3 \epsilon} \quad (2.36)$$



where  $T$  is the time period of oscillation of the current element and  $T = \frac{2\pi}{\omega}$ . The elementary area in spherical coordinates is  $2\pi r^2 \sin \theta d\theta$ , the total power radiated becomes

$$\begin{aligned} \oint_{\text{surface}} P_{r(av)} da &= \int_0^{\pi/2} \frac{\eta}{2} \left( \frac{\omega I dl \sin \theta}{4\pi c} \right)^2 2\pi r^2 \sin \theta d\theta = \frac{\eta \omega^2 I^2 dl^2}{16\pi c^2} \int_0^{\pi} \sin^3 \theta d\theta \\ \text{power} &= \frac{\eta \omega^2 I^2 dl^2}{16\pi c^2} \left[ \frac{-\cos \theta}{3} (2 + \sin^2 \theta) \right]_0^{\pi} = \frac{\eta \omega^2 I^2 dl^2}{12\pi c^2} \end{aligned} \quad (2.37)$$

We note from (2.37) that, the radiated power is inversely proportional to the square of operating frequency and current. If the carrier frequency increases, the power radiated into space also increases as its square. An increase in current gives rise to stronger magnetic and electric fields as is evident from the expressions for  $H_\phi$  and  $E_r, E_\theta$ . Hence, the radiation field is stronger for higher currents. In the above expression, the peak value of current has been used. The effective or the RMS current is, for a sinusoidal distribution

$$I_{rms} = \frac{I}{\sqrt{2}} \quad (2.38)$$

Substitution of (2.38) in (2.37) yields

$$\text{Power} = \frac{\eta \omega^2 I_{rms}^2 dl^2}{6\pi c^2} = 80\pi^2 \left( \frac{dl}{\lambda} \right)^2 I_{rms}^2 = 788.768 \left( \frac{dl}{\lambda} \right)^2 I_{rms}^2 \quad (2.39)$$

From (2.39), it appears that, the term  $80\pi^2 \left( \frac{dl}{\lambda} \right)^2$  has the appearance of a resistance as power is  $I^2 R$ . This resistance is defined as the radiation resistance and for a current element,

$$R_{rad} = 80\pi^2 \left( \frac{dl}{\lambda} \right)^2 \quad (2.40)$$

In (2.40), the dipole current is uniform. However, with no end loading, the current must be zero at the ends and if the dipole is short, the current tapers almost linearly from a maximum at the center to zero at the ends with an average value of  $\frac{1}{2}$  of the maximum.

We also note that, for lengths small compared to a wavelength, the radiation resistance is very small. For example, if  $\frac{dl}{\lambda} = 0.1$ , then  $R_{rad} = 0.08\pi^2$ . The value of the radiation resistance is an indicator of the power radiated by the antenna into space. Thus, this type of antenna is not a good radiator of EM power into space. A practical antenna such as an elementary dipole is a center-fed antenna. Its length is very short as compared to a wavelength at the carrier frequency. For the same current  $I$  at the terminals the practical dipole of length  $l$  radiates only one-quarter as much power as the current element of the same length which has the current  $I$  throughout its length. The radiation resistance of a practical short dipole is one-quarter that of the current element of the same length. That is

$$R_{rad}(\text{short dipole}) = 20\pi^2 \left(\frac{l}{\lambda}\right)^2 \approx 200 \left(\frac{l}{\lambda}\right)^2 \quad (2.41)$$

### 2.3 Radiation Resistance of a Loop Antenna

The field radiated by a small magnetic dipole is the dual of that radiated by a small electric current dipole short current filament. The source point (the elementary current length) is assumed to be in the  $xy$ -plane having a coordinate of  $(x', y', 0)$  and the observation point is assumed to be at  $(x, y, z)$ . The contribution of the current filament of strength  $Iad\phi$  to the total vector potential is found by the use of the equation

$$dA = \frac{\mu_0 Idl}{4\pi r} a_z \quad (2.42)$$

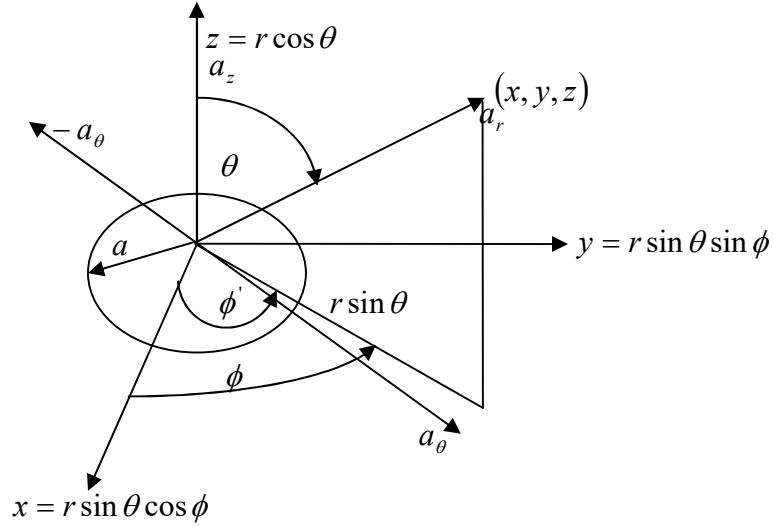

Fig.2.4 A loop in the  $xy$ -plane carrying a current  $I$  that produces a field at  $(x, y, z)$

(2.42) takes the form of

$$dA = \frac{\mu_0 I}{4\pi R} \exp(-j\beta R) (d\rho a_\rho + ad\phi' a_\phi) \quad (2.43)$$

This is due to the reason that the elementary current length is in the  $xy$ -plane. However, we may note immediately from Fig.2.2 that, the contribution to the field due to the  $\rho$  component will be canceled by a diametrically opposite current element. Therefore, (2.43) is simplified to

$$dA = \frac{\mu_0 I}{4\pi R} \exp(-j\beta R) (ad\phi' a_\phi) \quad (2.44)$$

$$\text{However, } a_x = -\sin \phi' a_\phi \text{ and } a_y = \cos \phi' a_\phi \quad (2.45)$$

Substitution of (2.44) into (2.43) gives us

$$dA = \frac{\mu_0 I a (-a_x \sin \phi' + a_y \cos \phi') d\phi' e^{-j\beta R}}{4\pi R} \quad (2.46)$$

$$\text{where } R = \left[ (x - a \cos \phi')^2 + (y - a \sin \phi')^2 \right]^{1/2} \quad (2.47)$$

### Method-I

$$\text{Thus, } A = \frac{\mu_0 I a}{4\pi} \exp(-j\beta R) \int_0^{2\pi} \frac{(-a_x \sin \phi' + a_y \cos \phi')}{R} d\phi' \quad (2.48)$$

We are primarily interested in the far field so that  $r \gg a$ . It is further assumed that  $a \ll \lambda$  so that the loop may be treated as a point source. In the spherical coordinate system,

$$\begin{aligned} R &= \left[ (x - x')^2 + (y - y')^2 + (z - z')^2 \right] \\ &= \left[ r^2 + a^2 - 2ra \sin \theta (\cos \phi \cos \phi' + \sin \phi \sin \phi') \right]^{1/2} \\ &= r \left[ 1 + \left( \frac{a}{r} \right)^2 - 2 \frac{a}{r} \sin \theta \cos(\phi - \phi') \right]^{1/2} \end{aligned} \quad (2.49)$$

$$\cong r \left[ 1 - \frac{a}{r} \sin \theta \cos(\phi - \phi') + \frac{1}{2} \left( \frac{a}{r} \right)^2 + \dots \right]$$

$$= r \left[ 1 - \frac{a}{r} \sin \theta \cos(\phi - \phi') \right]$$

as  $x = r \sin \theta \cos \phi$ ,  $y = r \sin \theta \sin \phi$  and  $z = r \cos \theta$ ,  $x' = a \cos \phi$  and  $y' = a \sin \phi$

(2.46) is approximated as

$$R \approx r - a \sin \theta (\cos \phi \cos \phi' + \sin \phi \sin \phi') \approx r - a \sin \theta \cos(\phi - \phi') \quad (2.47)$$

as  $a^2 \ll r^2$

Hence, substitution of (2.49) into (2.48) gives us

$$A = \frac{\mu_0 I a}{4\pi r} e^{-j\beta r} \int_0^{2\pi} e^{j\beta a \sin \theta \cos(\phi - \phi')} (-a_x \sin \phi' + a_y \cos \phi') d\phi' \quad (2.48)$$

$$A = \frac{\mu_0 I a}{4\pi r} e^{-j\beta r} \int_0^{2\pi} e^{j\beta a \sin \theta \cos(\phi - \phi')} \cos(\phi - \phi') a_\phi d\phi' \quad (2.49)$$

We further make an assumption that  $\beta a \ll 1$ . Hence, the exponential term may be expanded in a series and the higher orders in the expansion may be neglected. We obtain,

$$\begin{aligned} A &= \frac{\mu_0 I a}{4\pi r} e^{-j\beta r} \int_0^{2\pi} (1 + j\beta a \sin \theta \cos(\phi - \phi')) \cos(\phi - \phi') a_\phi d\phi' \\ &= \frac{\mu_0 I a}{4\pi r} e^{-j\beta r} \int_0^{2\pi} \cos(\phi - \phi') + j\beta a \sin \theta \cos^2(\phi - \phi') a_\phi d\phi' \end{aligned} \quad (2.50)$$

We note that, the integration of the first term in (2.50) gives us zero and that of the second term  $j\beta\pi a^2 \sin \theta$ . Hence, we obtain, the  $\phi$  component of the vector potential as

$$A = j\beta\pi \frac{\mu_0 I a^2}{4\pi R} e^{-j\beta r} \sin \theta a_\phi \quad (2.51)$$

The quantity  $\pi a^2 I$  is the product of the area of the circular loop of radius  $a$  and the current flowing through it and is known as the dipole moment of the small circular loop.

## Method-II

The same expression could have been derived by another way in the following manner. As before, under the assumption of  $\beta a \ll 1$  and using the series expansion of the exponential term, we obtain,

$$A = \frac{\mu_0 I a}{4\pi R} e^{-j\beta r} \int_0^{2\pi} (1 + j\beta a \sin \theta \cos(\phi - \phi')) (-a_x \sin \phi' + a_y \cos \phi') d\phi' \quad (2.52)$$

The integration of the first two terms in the above expression gives us zero.

Using  $\cos(\phi - \phi') = \cos \phi \cos \phi' + \sin \phi \sin \phi'$  and using in the above expression for the second term, we obtain,

$$\int_0^{2\pi} (\cos \phi \cos \phi' + \sin \phi \sin \phi') (-a_x \sin \phi' + a_y \cos \phi') d\phi' = \pi (\cos \phi a_y - \sin \phi a_x) = \pi a_\phi \quad (2.53)$$

$$\text{Hence, } A = \frac{\mu_0 I a}{4\pi R} e^{-j\beta r} j\beta a \sin \theta \pi a_\phi = j\beta \frac{\mu_0 I \pi a^2}{4\pi R} e^{-j\beta r} \sin \theta a_\phi \quad (2.54)$$

We also write,  $R \approx r - a \sin \theta \cos(\phi - \phi')$

Having obtained the vector potential, we can obtain the magnetic field and the corresponding electric field.

$$H = \nabla \times A_\phi = -\frac{1}{\mu_0 r} \frac{\partial}{\partial r} (r A_\phi) a_\phi = -\frac{\pi a^2 I \beta^2}{4\pi r} e^{-j\beta r} \sin \theta a_\phi = -\frac{M \beta^2}{4\pi r} e^{-j\beta r} \sin \theta a_\phi \quad (2.55)$$

The corresponding electric field is given as

$$E = -\eta a_r \times H_\phi = \frac{\eta M \beta^2}{4\pi r} e^{-j\beta a} a_\theta \quad (2.56)$$

The radiated power is

$$P_r = \frac{1}{2} (E \times H^*) = \frac{1}{2} \text{Re} \int_0^{2\pi} \int_0^\pi E_\theta H_\phi^* r^2 \sin \theta d\theta d\phi = \frac{\eta M^2 \beta^4}{16\pi^2} \int_0^{2\pi} \int_0^\pi \sin^3 \theta d\theta d\phi = \frac{\eta M^2 \beta^4}{12\pi} \quad (2.57)$$

The radiation resistance of the loop may be found by equating  $\frac{1}{2} |I|^2 R_a$  to  $P_r$ . So, we get

$$\frac{1}{2} |I|^2 R_a = \frac{\eta M^2 \beta^4}{12\pi} = \frac{120\pi (\pi a^2 I)^2}{12\pi} \beta^4 = 10 (\pi a^2)^2 \left(\frac{2\pi}{\lambda}\right)^4 I^2 \quad (2.58)$$

$$\text{Hence, } R_a = 20\pi^6 \left(\frac{a}{\lambda}\right)^4 \quad (2.59)$$

Let us consider a loop with a radius of 1cm operating at a frequency of 1 MHz, and substitution of these values into the above expression gives us a radiation resistance of

$R_a \approx 3.8 \times 10^{-9} \Omega$ . So a small loop antenna is a very poor radiator. If  $N$  turns of wire are used, the radiation resistance is increased by a factor of  $N^2$ . Small loop antennas are often used as receiving antennas for portable radios. Although they are very inefficient, they do give an acceptable performance because of the large available signal level. At low frequencies atmospheric noise is often the limiting factor, so a more efficient antenna does not necessarily give better reception. Of course, a small loop antenna would not be used for transmitting purposes unless very short distances were involved and the poor gain could be tolerated. The gain of a small loop antenna is very low because the ohmic resistance of the wire is generally much greater than the radiation resistance.

**Ex. 2.1:** Two  $z$  directed Hertzian dipoles are in phase and a distance of  $d$  apart. The electric field intensity is given by

$$E_\theta = \frac{j\beta\eta(Idl)}{2\pi r} e^{-j\beta r} \sin\theta \cos\left(\beta \frac{d}{2} \sin\theta \sin\phi\right)$$

In deriving this expression, use has been made of

$$y = r \cos\alpha = r \sin\theta \sin\phi$$

The corresponding magnetic field strength is given as

$$H_\phi = \frac{j\eta(Idl)}{2\pi r} e^{-j\beta r} \sin\theta \cos\left(\beta \frac{d}{2} \sin\theta \sin\phi\right)$$

Thus, the power radiated becomes

$$P_{avg} = \frac{1}{2} \text{Re}(E \times H^*) = \frac{1}{2} \left( \frac{\beta\eta Idl}{2\pi r} \cdot \frac{\beta Idl}{2\pi r} \right) \sin\theta \cdot \sin\theta$$

The radiated power is obtained by taking the integral of the above over an elementary surface.

$$P_{rad} = \int_0^{2\pi} \int_0^\pi \frac{1}{2} \left( \frac{\beta\eta Idl}{2\pi r} \cdot \frac{\beta Idl}{2\pi r} \right) \sin^2\theta r^2 \sin\theta d\theta d\phi = \frac{\beta^2 \eta}{8\pi^2} (Idl)^2 \int_0^{2\pi} \int_0^\pi \sin^3\theta d\theta d\phi$$

Making use of the integral

$$\int \sin^n ax dx = -\frac{\sin ax \cos ax}{na} + \frac{n-1}{n} \int \sin^{n-2} ax dx, \text{ we note that}$$

$$\int_0^\pi \sin^3\theta d\theta = \left| -\frac{\sin^2\theta \cos\theta}{3} \right|_0^\pi + \frac{2}{3} \int_0^\pi \sin\theta d\theta = \left| -\frac{\sin^2\theta \cos\theta}{3} \right|_0^\pi - \frac{2}{3} |\cos\theta|_0^\pi = \frac{4}{3}$$

$$P_{rad} = \frac{\beta^2 \eta}{8\pi^2} (Idl)^2 \cdot \frac{4}{3} \int_0^{2\pi} d\phi = \frac{\beta^2 \eta}{8\pi^2} (Idl)^2 \cdot \frac{4}{3} \cdot 2\pi = \frac{\beta^2 \eta}{3\pi} (Idl)^2$$

We make use of  $\beta = \frac{2\pi}{\lambda}$  in the above to get

$$P_{rad} = \left( \frac{2\pi}{\lambda} \right)^2 \cdot \frac{\eta (Idl)^2}{3\pi} = \frac{4\pi\eta}{3} \left( \frac{Idl}{\lambda} \right)^2$$

## 2.4 DIRECTIVITY

The ability of an antenna or an array of antennas to concentrate the radiated power in a given direction, or conversely to absorb effectively incident power from that direction is specified variously in terms of its gain, power gain, directive gain or directivity.

The magnetic field is obtained from the magnetic vector potential by taking its curl. In spherical coordinates, it is expressed as

$$\begin{aligned}\nabla \times A &= \frac{1}{r^2 \sin \theta} \begin{bmatrix} a_r & ra_\theta & r \sin \theta a_\phi \\ \frac{\partial}{\partial r} & \frac{\partial}{\partial \theta} & \frac{\partial}{\partial \phi} \\ A_r & rA_\theta & r \sin \theta A_\phi \end{bmatrix} \\ &= \frac{1}{r^2 \sin \theta} \left[ \left( r \sin \theta \frac{\partial A_\phi}{\partial \theta} - r \frac{\partial A_\theta}{\partial \phi} \right) a_r - r \left( r \sin \theta \frac{\partial A_\phi}{\partial r} - \frac{\partial A_r}{\partial \phi} \right) a_\theta + r \sin \theta \left( \frac{r \partial A_\theta}{\partial r} - \frac{\partial A_r}{\partial \theta} \right) a_\phi \right]\end{aligned}\quad (2.60)$$

Under the assumption of the wave propagating along the radial direction from the current source, we note that the electric and the magnetic fields would lie in the  $\theta - \phi$  plane.

Therefore, (2.60) reduces to

$$\begin{aligned}\nabla \times A &= \frac{1}{r^2 \sin \theta} \left[ r \sin \theta \left( \frac{r \partial A_\theta}{\partial r} - \frac{\partial A_r}{\partial \theta} \right) a_\phi - r \left( r \sin \theta \frac{\partial A_\phi}{\partial r} - \frac{\partial A_r}{\partial \phi} \right) a_\theta \right] \\ &= \frac{1}{r} \left( \frac{r \partial A_\theta}{\partial r} - \frac{\partial A_r}{\partial \theta} \right) a_\phi - \left( \frac{\partial A_\phi}{\partial r} - \frac{1}{r \sin \theta} \frac{\partial A_r}{\partial \phi} \right) a_\theta \\ &= \frac{\partial A_\theta}{\partial r} a_\phi - \frac{\partial A_\phi}{\partial r} a_\theta\end{aligned}\quad (2.61)$$

This is due to the fact that the radial component  $A_r$  does not exist or  $A_r = 0$ . As the magnetic vector potential has components constrained to lie in the  $\theta - \phi$  plane, we can also express (2.61) as the following.

Let us define a vector potential

$$A_T = A_\theta(r, \theta, \phi) a_\theta + A_\phi(r, \theta, \phi) a_\phi \quad (2.62)$$

$$\text{Using the fact that } a_\theta \times a_r = a_\phi, a_r \times a_\phi = a_\theta \text{ and } a_\phi \times a_\theta = a_r \quad (2.63)$$

We may observe that,

$$\begin{aligned}a_r \times A_T &= a_r \times [A_\theta(r, \theta, \phi) a_\theta + A_\phi(r, \theta, \phi) a_\phi] \\ &= -A_\theta(r, \theta, \phi) a_\phi + A_\phi(r, \theta, \phi) a_\theta\end{aligned}\quad (2.64)$$

$$\begin{aligned}\nabla \times A &= \frac{\partial A_\theta}{\partial r} a_\phi - \frac{\partial A_\phi}{\partial r} a_\theta \\ &= -a_r \times A_T\end{aligned}\quad (2.65)$$

Let us consider very generic expressions for the two components of the magnetic field vector as the following:

$$A_\theta(r, \theta, \phi) = \frac{1}{r} A_{\theta 0}(\theta, \phi) \exp(-j\beta r) \quad (2.66a)$$

And similarly,

$$A_\phi(r, \theta, \phi) = \frac{1}{r} A_{\phi 0}(\theta, \phi) \exp(-j\beta r) \quad (2.66b)$$

Therefore, the first term of (2.61) becomes

$$\begin{aligned} r \frac{\partial A_\theta}{\partial r} &= r \left[ -\frac{1}{r^2} A_{\theta 0}(\theta, \phi) \exp(-j\beta r) - j \frac{\beta}{r} A_{\theta 0}(\theta, \phi) \exp(-j\beta r) \right] \\ &= -[A_{\theta 0}(\theta, \phi) \exp(-j\beta r)] \left( \frac{1}{r} + j\beta \right) \end{aligned} \quad (2.67a)$$

Similarly,

$$\begin{aligned} \frac{\partial A_\phi}{\partial r} &= -\frac{1}{r^2} A_{\phi 0}(\theta, \phi) \exp(-j\beta r) - j \frac{\beta}{r} A_{\phi 0}(\theta, \phi) \exp(-j\beta r) \\ &= -\frac{1}{r} [A_{\phi 0}(\theta, \phi) \exp(-j\beta r)] \left( \frac{1}{r} + j\beta \right) \end{aligned} \quad (2.67b)$$

The radiated field components correspond to the terms containing  $\frac{1}{r}$  only. Hence, we retain the term  $-j\beta [A_{\theta 0}(\theta, \phi) \exp(-j\beta r)]$  from (2.67a) and  $-\frac{j\beta}{r} [A_{\phi 0}(\theta, \phi) \exp(-j\beta r)]$  from (2.67b). The total contribution to the magnetic vector potential is,

$$\begin{aligned} \nabla \times A &= -\frac{j\beta}{r} [A_{\theta 0}(\theta, \phi) \exp(-j\beta r) a_\phi - A_{\phi 0}(\theta, \phi) \exp(-j\beta r) a_\theta] \\ &= -j\beta [A_\theta(r, \theta, \phi) a_\phi - A_\phi(r, \theta, \phi) a_\theta] \\ &= j\beta [A_\phi(r, \theta, \phi) a_\theta - A_\theta(r, \theta, \phi) a_\phi] = B \end{aligned} \quad (2.68)$$

We have made use of (2.67) in deriving (2.68). We, therefore, obtain the magnetic field as

$$\begin{aligned} H &= \frac{B}{\mu} = \frac{1}{\mu} \nabla \times A = j \frac{\beta}{\mu} [A_\phi(r, \theta, \phi) a_\theta - A_\theta(r, \theta, \phi) a_\phi] \\ &= j \frac{2\pi}{\lambda \mu} [A_\phi(r, \theta, \phi) a_\theta - A_\theta(r, \theta, \phi) a_\phi] = j \frac{2\pi}{(c/f)\mu} [A_\phi(r, \theta, \phi) a_\theta - A_\theta(r, \theta, \phi) a_\phi] \\ &= -\frac{j\omega}{c\mu} a_r \times A_T \end{aligned} \quad (2.69)$$

where we have made use of (2.65).

$$\text{Further, } c\mu = \frac{\mu}{\sqrt{\mu\epsilon}} = \sqrt{\frac{\mu}{\epsilon}} = \frac{1}{\eta} \quad (2.70)$$

Hence, the magnetic field can also be expressed as

$$H = -\frac{j\omega}{c\mu} a_r \times A_T = -j \frac{\omega}{\eta} a_r \times A_T \quad (2.71)$$

The electric field associated with (2.71) is evaluated as

$$\begin{aligned}
E &= \frac{1}{j\omega\epsilon} (\nabla \times H) \\
&= \frac{1}{j\omega\epsilon} \left\{ \nabla \times \frac{j\omega}{c\mu} [A_\phi(r, \theta, \phi)a_\theta - A_\theta(r, \theta, \phi)a_\phi] \right\} \\
&= c \left\{ \nabla \times [A_\phi(r, \theta, \phi)a_\theta - A_\theta(r, \theta, \phi)a_\phi] \right\}
\end{aligned} \tag{2.72}$$

To evaluate (2.72) we note that, a similar expression appears in (2.61). Here, the radial component is nonexistent. Hence,

$$\begin{aligned}
\nabla \times H &= \frac{1}{r^2 \sin \theta} \begin{bmatrix} a_r & ra_\theta & r \sin \theta a_\phi \\ \frac{\partial}{\partial r} & \frac{\partial}{\partial \theta} & \frac{\partial}{\partial \phi} \\ 0 & rA_\phi & -r \sin \theta A_\theta \end{bmatrix} \\
&= \frac{1}{r^2 \sin \theta} \left[ \left( -r \sin \theta \frac{\partial A_\phi}{\partial \theta} - \frac{\partial}{\partial \phi} rA_\theta \right) a_r - r \left( -r \sin \theta \frac{\partial A_\theta}{\partial r} \right) a_\theta + r \sin \theta \left( \frac{r \partial A_\phi}{\partial r} \right) a_\phi \right] \\
&= \frac{1}{r^2 \sin \theta} \left[ r^2 \sin \theta \left( \frac{\partial A_\theta}{\partial r} \right) a_\theta + r^2 \sin \theta \frac{\partial A_\phi}{\partial r} a_\phi \right] \\
&= \frac{\partial A_\theta}{\partial r} a_\theta + \frac{\partial A_\phi}{\partial r} a_\phi
\end{aligned} \tag{2.73}$$

We may note that,

$$\begin{aligned}
\frac{\partial A_\theta}{\partial r} &= -\frac{1}{r^2} A_{\theta 0}(r, \theta, \phi) \exp(-j\beta r) - \frac{j\beta}{r} A_{\theta 0}(r, \theta, \phi) \exp(-j\beta r) \\
&= -\frac{1}{r} A_{\theta 0}(r, \theta, \phi) \exp(-j\beta r) \left( \frac{1}{r} + j\beta \right)
\end{aligned} \tag{2.74}$$

A similar expression may be obtained for  $\frac{\partial A_\phi}{\partial r}$ . Combining these two together, we have an expression for the radiated electric field as

$$\begin{aligned}
E &= c \left[ -\frac{j\beta}{r} A_{\theta 0}(r, \theta, \phi) \exp(-j\beta r) a_\theta - \frac{j\beta}{r} A_{\phi 0}(r, \theta, \phi) \exp(-j\beta r) a_\phi \right] \\
&= -j\beta c [A_\theta(r, \theta, \phi) a_\theta + A_\phi(r, \theta, \phi) a_\phi] = -j\omega A_r
\end{aligned} \tag{2.75}$$

The generic expressions for the radiated electric field and the magnetic field are given by (2.75) and (2.71) respectively when the wave propagates along a radial direction from the source. The power radiated per unit area in any direction is given by the Poynting vector  $P$ . For the distant or radiation field for which the electric field and the magnetic field are orthogonal in a plane perpendicular to the radius vector, and for which  $E = \eta_v H$ , the power flow per unit area is given by

$$P = \frac{E^2}{\eta_v} = \eta_v H = E \times H \tag{2.76}$$

The radiation intensity  $\Phi(\theta, \phi)$  in a given direction is defined as the power per unit solid angle in that direction. This takes the form of



$$\Phi(\theta, \phi) = r^2 P = \frac{r^2 E^2}{\eta_v} \text{ watts/unit solid angle} \quad (2.77)$$

The radiation intensity is independent of the radial distance. The total power radiated is

$$W_r = \int \Phi d\Omega \text{ watts} \quad (2.78)$$

Since there are  $4\pi$  steradians in the total solid angle, the average power radiated per

unit solid angle is  $\frac{W_t}{4\pi}$ .

The directive gain or the directivity is defined as the ratio of the radiation intensity in that direction to the average radiated power. That is,

$$G(\theta, \phi) = \frac{\Phi(\theta, \phi)}{\Phi_{av}} = \frac{\Phi(\theta, \phi)}{W_t/4\pi} = \frac{4\pi\Phi(\theta, \phi)}{W_t} = \frac{4\pi\Phi(\theta, \phi)}{\int \Phi d\Omega} \quad (2.79)$$

For a current element  $Idl$ , the distant field in the direction of maximum radiation is, from (2.32)

$$E = \frac{60\pi}{r} I \left( \frac{dl}{\lambda} \right) \quad (2.80)$$

The current required to radiate 1 watt is, therefore, from (2.39)

$$I = \frac{\lambda}{\sqrt{80\pi dl}} \text{ A} \quad (2.81)$$

Substitution of (2.81) in (2.80) gives us a corresponding field strength in the direction of maximum radiation as

$$E = \frac{60\pi}{r} \cdot \frac{\lambda}{\sqrt{80\pi dl}} \cdot \frac{dl}{\lambda} = \frac{60\pi}{r\sqrt{80}} \text{ V/m} \quad (2.82)$$

The radiation intensity is

$$\Phi = \frac{r^2 E^2}{\eta} = \frac{60^2}{80 \times 120\pi} = \frac{3}{8\pi} \quad (2.83)$$

so that the directivity or maximum gain of the current element is

$$g_d(\text{max}) = 4\pi\Phi = 1.5 \quad (2.84)$$

The above expression states that for a current element the computed directivity is 1.5. Next, let us evaluate the directivity of a half wave dipole by considering its radiated field expressions. The Poynting vector power density for the half-wave dipole is maximum at

$\theta = \frac{\pi}{2}$  and hence the effective or the RMS value of the electric field is

$$E_\theta(\text{rms}) = \frac{60I_{\text{rms}}}{r} \quad (2.85)$$

The radiated power is

$$\begin{aligned} P_r &= \frac{E_\theta(\text{rms})^2}{\eta} = \frac{1}{120\pi} \left( \frac{60I_{\text{rms}}}{r} \right)^2 \\ &= \frac{30I_{\text{rms}}^2}{\pi r^2} \end{aligned} \quad (2.86)$$

$$\text{The power input to the dipole is } R_{\text{rad}} I_{\text{rms}}^2 = 73I_{\text{rms}}^2 \quad (2.87)$$

From (2.87) we observe that, the radiation resistance of a half wave dipole is  $73 \Omega$ . Hence, the directive gain of the half wave dipole is

$$G = \frac{4\pi r^2 \cdot \frac{30I_{rms}^2}{\pi r^2}}{73I_{rms}^2} = \frac{120}{73} = 1.64 \quad (2.88)$$

We can also evaluate the directivity of a half wave dipole in the following manner. For a half-wave dipole, the maximum field strength is

$$E = \frac{60I_m}{r} \text{ V/m} \quad (2.89)$$

The effective or the RMS value of the electric field is, therefore

$$E_{rms} = \frac{60I_{rms}}{r} \quad (2.90)$$

The current required to radiate 1 watt is  $\frac{1}{\sqrt{73}}$  amps. This can be verified from (2.87).

The corresponding field strength in the direction of maximum radiation is obtained by substituting this value in (2.90) and this is, therefore,

$$E = \frac{60}{r} \sqrt{\frac{1}{73}} \quad (2.91)$$

The radiation intensity is

$$\Phi = \frac{r^2 E^2}{\eta} = \frac{r^2 \cdot 60^2 \frac{1}{73}}{r^2 \eta} = 60^2 \frac{1}{73 \times 120\pi} \quad (2.92)$$

Hence its directivity is

$$G(\max) = 4\pi\Phi = 60^2 \frac{1}{73 \times 120\pi} \cdot 4\pi = \frac{60 \times 60}{73 \times 30} = \frac{120}{73} = 1.64 \quad (2.93)$$

We next relate the electric field strength and the effective radiated power. As the power radiated is proportional to the square of the RMS value of the current,

$$\text{Thus, } I_{rms} = \sqrt{\frac{W}{36.5}} \quad (2.94)$$

Substitution of the above value of the RMS current in the field strength expression gives us

$$E = \frac{60}{r} \sqrt{\frac{W}{36.5}} = \frac{9.9313}{r} \sqrt{W} \text{ V/m} \quad (2.95)$$

One mile = 1609.344 meters = 1.609344 Km

The above RMS field strength for a distance of 1 mile is (2.96)

$$\frac{9.9313}{r \times 1609.344} \sqrt{W} = \frac{6.14}{r} \sqrt{W} \text{ mV/m}$$

Next we set up the vector potential due to a traveling wave current distribution in the  $z$  direction given by  $I(z) = I_m e^{j\beta z}$

## MODULE-III

### 3.1 LINEAR ANTENNA

A linear antenna is assumed to be made up of a large number of very short conductors connected in series. A conductor having a length of  $\frac{\lambda}{2}$  is shown in Fig.1. The two ends of the conductor are at opposite voltages. The RF energy from the transmitter is fed at its center because the dipole antenna is a symmetrical antenna in which the two ends are at equal potentials relative to the mid-point. At the open-ends, the current is zero and the voltage is maximum. The radiation pattern represents the field strength in various directions of an open ended half-wave antenna. For the opened out half wave conductor, the magnetic field will be maximum along a line extending from the its center and electric fields will be perpendicular to it.

The half-wave dipole (Fig to be inserted) derives its name from the fact that its length is half a wavelength  $l = \frac{\lambda}{2}$ . It consists of a thin wire fed or excited at its midpoint by a voltage source connected to the antenna through a transmission line. The field due to the dipole may be considered to be consisting of a chain of Hertzian dipoles. The magnetic vector potential at a point P due to a differential length  $dl = dz$  of the dipole carrying a phasor current  $I_s = I_0 \cos \beta z$  is

$$dA = \frac{\mu I_0 \cos \beta z}{4\pi r'} e^{-j\beta r r'} \quad (3.1)$$

A sinusoidal current distribution has been assumed here for two reasons. First it is due to the transmission line model of the dipole. Second, the current must be zero at the ends of the dipole. Thus one may consider a triangular distribution of the current also. However, it is likely to yield a less accurate result. We write

$$\begin{aligned} r &= r' - z \cos \theta \\ \text{or } r' &= r - z \cos \theta \end{aligned} \quad (3.2)$$

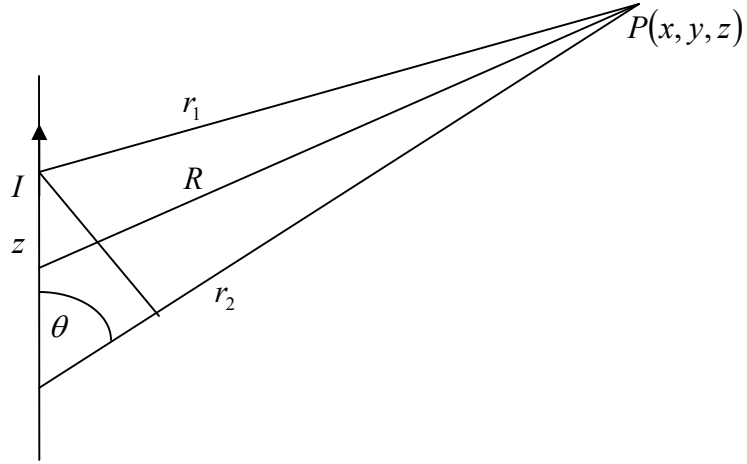

Fig.3.1 An electric dipole

The difference between  $\beta r$  and  $\beta r'$  is quite significant. Hence, the above magnetic vector potential is written as

$$dA = \frac{\mu I_0 \cos \beta z}{4\pi r} e^{-j\beta(r-z \cos \theta)} \quad (3.3)$$

The total magnetic vector potential becomes

$$A = \frac{\mu I_0 e^{-j\beta r}}{4\pi r} \int_{-\frac{\lambda}{4}}^{\frac{\lambda}{4}} e^{j\beta z \cos \theta} \cos \beta z dz \quad (3.4)$$

We understand that

$$\int e^{az} \cos bz dz = \frac{e^{az} (a \cos bz + b \sin bz)}{a^2 + b^2} + c \quad (3.5)$$

Substitution of (3.5) in the total magnetic vector potential given as in (3.4) gives

$$A_z = \frac{\mu I_0 e^{-j\beta r} e^{j\beta z} \cos \theta}{4\pi r} \left. \frac{(j\beta \cos \theta + \beta \sin bz)}{-\beta^2 \cos^2 \theta + \beta^2} \right|_{-\frac{\lambda}{4}}^{\frac{\lambda}{4}} \quad (3.6)$$

Further, since  $\beta = \frac{2\pi}{\lambda}$  or  $\frac{\beta\lambda}{4} = \frac{\pi}{2}$  and  $1 - \cos^2 \theta = \sin^2 \theta$ , then

$$\begin{aligned} A_z &= \frac{\mu I_0 e^{-j\beta r}}{4\pi \beta^2 \sin^2 \theta} \left[ e^{j\left(\frac{\pi}{2}\right) \cos \theta} (0 + \beta) - e^{-j\left(\frac{\pi}{2}\right) \cos \theta} (0 - \beta) \right] \\ &= \frac{\mu I_0 e^{-j\beta r} \cos\left(\frac{\pi}{2} \cos \theta\right)}{2\pi \beta \sin^2 \theta} \end{aligned} \quad (3.7)$$

In this section, we will derive a general expression for the distant electric field of a dipole antenna of any half-length  $H$ . The total vector potential at point P is

$$A_z = \frac{\mu}{4\pi} \int_{-H}^0 \frac{I_m \sin \beta(H+z) e^{-j\beta r}}{R} dz + \frac{\mu}{4\pi} \int_0^H \frac{I_m \sin \beta(H-z) e^{-j\beta r}}{R} dz \quad (3.8)$$

Because of the approximation  $R \approx r$ , we write (2.104) as

$$A_z = \frac{\mu I_m}{4\pi} \left[ \int_{-H}^0 \frac{\sin \beta(H+z) e^{-j\beta z \cos \theta}}{r} dz + \int_0^H \frac{\sin \beta(H-z) e^{-j\beta z \cos \theta}}{r} dz \right] \quad (3.9)$$

We make use of the following integral to evaluate the above.

$$\int e^{ax} \sin bx dx = \frac{e^{ax}}{a^2 + b^2} (a \sin bx - b \cos bx)$$

In the first term in the RHS of (3.9), it is noted that,  $a = j\beta \cos \theta$  and  $b = \beta$

Thus, with this the first term in the RHS of (3.9) becomes.

$$\begin{aligned} \frac{\mu I_m}{4\pi} \int_{-H}^0 \frac{\sin \beta(H+z) e^{-j\beta z \cos \theta}}{r} dz &= \frac{\mu I_m}{4\pi r} \left| \frac{e^{j\beta \cos \theta}}{\beta^2 (1 - \cos^2 \theta)} \right. \left. [j\beta \cos \theta \sin \beta(H+z) - \beta \cos \beta(H+z)] \right|_{-H}^0 \\ &= \frac{\mu I_m}{4\pi r \beta^2 \sin^2 \theta} [j\beta \cos \theta \sin \beta H - \beta \cos \beta H - e^{-j\beta H \cos \theta} (-\beta)] \end{aligned}$$

Similarly, the second term in the RHS of (3.9) becomes

$a = j\beta \cos \theta$  and  $b = -\beta$

$$\frac{\mu I_m}{4\pi} \int_0^H \frac{\sin \beta(H-z) e^{-j\beta z \cos \theta}}{r} dz = \frac{\mu I_m}{4\pi r} \left| \frac{e^{j\beta \cos \theta}}{\beta^2 (1 - \cos^2 \theta)} \right. \left. [j\beta \cos \theta \sin \beta(H-z) + \beta \cos \beta(H-z)] \right|_0^H$$

which is equal to

$$\frac{\mu I_m}{4\pi r \beta^2 \sin^2 \theta} [-j\beta \cos \theta \sin \beta H - \beta \cos \beta H - e^{-j\beta H \cos \theta} (-\beta)]$$

Combining the two, we obtain

$$A_z = \frac{\mu I_m}{4\pi r \beta^2 \sin^2 \theta} [2\beta \cos(\beta H \cos \theta) - 2\beta \cos \beta H] = \frac{\mu I_m e^{-j\beta r}}{2\pi r \beta \sin^2 \theta} (\cos(\beta H \cos \theta) - \cos \beta H) \quad (3.10)$$

We recall that when the current is entirely in the  $z$  direction,

$$\mu H_\phi = -\sin \theta \frac{\partial A_z}{\partial r}$$

Differentiation of (3.10) w.r.t. the radial distance  $r$  gives us the expression for the magnetic field strength at a distant point as

$$H_\phi = \frac{j I_m e^{-j\beta r} (\cos(\beta H \cos \theta) - \cos \beta H)}{2\pi r \sin \theta} \quad (3.11)$$

where only the inverse distance term has been retained. The electric field strength corresponding to the radiation field will be

$$E_\theta = \frac{j 60 I_m e^{-j\beta r} (\cos(\beta H \cos \theta) - \cos \beta H)}{r \sin \theta} \quad (3.12)$$

From this, we note that, the electric field and the magnetic field are in time phase. The power density is expressed as

$$P = E_\theta \times H_\phi = \frac{30I_m^2}{\pi r^2} \left[ \frac{\cos(\beta H \cos \theta) - \cos \beta H}{\sin \theta} \right]^2 \quad (3.13)$$

A resonant antenna corresponds to a resonant transmission line and the dipole antenna is a resonant antenna. Such an antenna may be viewed as an open-circuited transmission line, open-circuited at the far end of the resonant length, i.e. a multiple of quarter-wavelength so that the length of the antenna is a multiple of half-wavelengths. The radiation pattern is a line drawn to join points in space which have equal field intensity due to the source.

### 3.2 NONRESONANT ANTENNA

A nonresonant antenna is like a nonresonant transmission line on which there are no standing waves. These are suppressed by the use of a correct termination to ensure that no power is reflected thus ensuring the presence of a traveling wave only. In a correctly matched transmission line, all the transmitted power is dissipated in the terminating resistance. When an antenna is terminated similar to a transmission line, about two-thirds of the input power is radiated, the remaining one third is dissipated in the antenna and none is reflected to the input. An example is a Rhombic antenna that is used for point-to-point working in the HF range spanning a frequency range of 3-to 30-MHz. It is a broadband antenna. For the terminated antennas having only a traveling wave distribution of current, we derive next the pattern of these next.

For a distant point P located at a distance of  $R$  from the origin, we note that, the elementary vector potential is expressed as

$$dA_z = \frac{\mu I_m}{4\pi R} e^{-j\beta r} dz$$

$$R = r - z \cos \theta$$

For the distant field calculation,

$$R \approx r$$

$$\text{Hence, } dA_z = \frac{\mu I_m e^{-j\beta z}}{4\pi r} e^{-j\beta(r-z \cos \theta)} dz$$

$$\text{Thus, } A_z = \int_0^L dA_z = \frac{\mu I_m e^{-j\beta r}}{4\pi r} \int_0^L e^{-j\beta z(1-\cos \theta)} dz = \frac{\mu I_m e^{-j\beta r}}{4\pi r} \cdot \frac{1}{j\beta(1-\cos \theta)} \left[ e^{-j\beta z(1-\cos \theta)} \right]_0^L$$

Evaluating the integral, we obtain

$$A_z = \frac{\mu I_m e^{-j\beta r}}{4\pi r} \cdot \frac{1}{j\beta(1-\cos \theta)} \left[ -1 + e^{j\beta(1-\cos \theta)L} \right] = \frac{\mu I_m e^{-j\beta r}}{4\pi r} \cdot \frac{1}{j\beta(1-\cos \theta)} \left[ 1 - e^{j\beta(1-\cos \theta)L} \right]$$

We recall that when the current is entirely in the  $z$  direction,

$$\mu H_\phi = -\sin \theta \frac{\partial A_z}{\partial r}$$

Hence, the magnetic field strength in the perpendicular direction is

$$H_{\phi} = -\sin \theta \frac{I_m e^{-j\beta r}}{4\pi r} \cdot \frac{1}{j\beta(1-\cos \theta)} [1 - e^{j\beta(1-\cos \theta)L}] = -\sin \theta \cdot j\beta \cdot \frac{I_m}{4\pi r \cdot j\beta(1-\cos \theta)} [1 - e^{j\beta(1-\cos \theta)L}]$$

This becomes, after simplifying,

$$H_{\phi} = \frac{I_m \sin \theta \cdot e^{-j\beta r}}{4\pi r(1-\cos \theta)} [1 - e^{-j\beta L(1-\cos \theta)}]$$

The electric field intensity is expressed as

$$E_{\theta} = 120\pi H_{\phi} = \frac{30I_m \cdot e^{-j\beta r}}{4\pi r(1-\cos \theta)} [1 - \cos \beta L(1-\cos \theta) + j \sin \beta L(1-\cos \theta)]$$

Thus, the magnitude of the electric field is

$$E_{\theta} = \frac{30I_m}{r(1-\cos \theta)} [2 - 2 \cos \beta L(1-\cos \theta)]^{\frac{1}{2}}$$

It is observed from the above expression that with a traveling wave the pattern is no longer symmetrical about the  $\theta = \frac{\pi}{2}$  degrees plane, but instead the radiation tends to lean in the direction of the current wave. The angle  $\theta$  between the axis of the antenna and the direction of maximum radiation becomes smaller as the antenna and the direction of maximum radiation becomes smaller as the antenna becomes longer. For the standing wave current distribution, the pattern is always symmetrical about the  $\theta = \frac{\pi}{2}$  degrees plane.

### 3.3 LOOP AND FERRITE ROD RECEIVING ANTENNAS

The loop antenna is made up of one or more turns of wire on a frame, which may be rectangular or circular and is very much smaller than one wavelength across. The antenna is popular for two reasons: (1) it is relatively compact, lending itself to use with portable receivers; and (2) it is quite directive, lending itself to use with direction-finding equipment. A loop antenna made of several turns of wire around a rectangular frame were popular for earlier model broadcast receivers, with the loop being mounted in the back of the cabinet. Recently, these have been replaced by ferrite-rod antennas. When the loop is aligned for maximum signal strength, the magnetic flux linkages are  $BAN$  where  $B$  is the rms magnetic flux density in Tesla,  $A$  is the physical loop area in square meter and  $N$  is the number of turns. The induced emf is given by

$$V_s = \omega NBA$$

When the loop is tuned by means of an external capacitor to the received frequency, the voltage at the capacitor terminals is magnified by the quality factor  $Q$  of the circuit.

Hence, the capacitor voltage becomes

$$V_{\max} = V_s Q = Q \omega NBA$$

Since the loop is usually much smaller than the received wavelength, the induced voltage may be quite small. It may be increased by increasing any one of the factors as shown above. The  $Q$  is determined by the desired selectivity. The area must be kept small; increasing the number of turns increases the coil inductance and changes  $Q$ , and even changing the flux density affects the  $Q$ . However, changing the flux density by using a

magnetic core can be achieved with a minimal change of  $Q$  using ferrite cores. This has been preferred now. The loop antenna is usually used as a direction finding device.

The ferrite-rod antenna is made by winding a coil of wire on a ferrite rod similar to the one shown in Fig. Ferrites are materials that exhibit the properties of ferromagnetism. The materials exhibit a high relative permeability in the same manner as magnetic materials do, but unlike the ferromagnetic metals, they also have a high bulk resistivity. This means that at high frequencies, eddy currents induced within the materials are practically nonexistent and high- $Q$  coils can be used. A high length-to-diameter ratio for the rod gives a high permeability, which is desirable.

The size of the coil is a compromise among several factors. If the coil is too long compared to the rod length, the change of permeability with temperature will cause a noticeable change in the inductance. If it is too short, the  $Q$  will be low. Positioning the coil on the core is critical as well, since the effective permeability is a function of position of the rod, changing from maximum at the center to a minimum at either end. The coil is usually placed near the quarter-point, allowing adjustment in either direction to trim the coil inductance. When more than one coil is mounted on the same rod, they must be placed at opposite ends to minimize interaction between them.

The coil of wire on the ferrite rod is basically a modified loop antenna, so the induced maximum emf appearing at its terminals is given by

$$V_s = \omega BANF\mu_r$$

where  $F$  is the modifying factor accounting for coil length, ranging from unity for short coils to about 0.7 for one that extends the full length of the rod,  $\mu_r$  is the effective relative permeability of the rod, as measured for the actual coil position and  $A$  is the rod cross-sectional area

Since the voltage appearing at the terminals is of more importance in a receiving antenna, the factor  $Ql_{eff}$  is often given as a figure of merit for rod antennas. The directional properties of the ferrite-rod antenna are similar to those of the loop antenna, although the null may not be quite so pronounced.

A term that has special significance for the receiving antennas is its effective area (sometimes also called the effective aperture). It is defined in terms of the directive gain of the antenna through the relation

$$A = \frac{\lambda^2}{4\pi} g_d$$

The effective area is thus the ratio of power available at the antenna terminals to the power per unit area of the appropriately polarized incident wave. That is

$$W_R = PA$$

where  $W_R$  is the received power and  $P$  is the power flow per square meter for the incident wave. When the directivity is used in the expression of the effective area it is assumed that all of the available power is delivered to the load. This is the case for a 100 per cent efficient correctly matched receiving antenna with the proper polarization



characteristics. For an effective field strength  $E$  parallel to the antenna the power per square meter in the linearly polarized received wave is

$$P = \frac{E^2}{\eta} = \frac{E^2}{120\pi} \text{ watts/sq m}$$

The power is absorbed in a properly matched load connected to the antenna would be

$$W_R = \frac{V_{oc}^2}{4R_{rad}} = \frac{E^2 l_{eff}^2}{4R_{rad}}$$

For a current element  $l_{eff} = dl$  and hence

$$W_R = \frac{E^2 dl^2}{4R_{rad}}$$

Substitution of the value of the radiation resistance in the above gives us

$$W_R = \frac{E^2 dl^2}{4R_{rad}} = \frac{E^2 dl^2}{4.80\pi^2} \left( \frac{\lambda}{dl} \right)^2 = \frac{E^2 \lambda^2}{320\pi^2}$$

Hence the maximum effective area is

$$A = \frac{W_R}{P} = \frac{E^2}{120\pi} \div \frac{E^2 \lambda^2}{320\pi^2} = 1.5 \frac{\lambda^2}{4\pi}$$

### 3.4 TELEVISION ANTENNA

The basic antenna for TV transmission and reception that make use of the VHF band of frequencies (30-300MHz) is the half-wave dipole antenna. This is called a resonant antenna as it gives out its best performance only at a particular frequency relative to its length. For antennas close to earth, vertically polarized EM waves yield better SNR. However, when the antenna is several wavelengths above the ground, horizontally polarized waves yield better SNR. The TV signals are transmitted by space wave propagation and hence the antenna height must be as high as possible in order to increase the line-of-sight distance. Horizontal polarization is the standard for TV broadcasting. Horizontal polarization indicates the plane of the electric field. Such a polarization is preferred because of the availability of good signal-to-noise ratio (SNR) when antennas are placed quite high above the surface of earth. For maximum signal pick-up, the receiving antenna should have the same polarization as that of the transmitted signal and this is the reason why the TV receiving antennas are aligned horizontally.

### LONG WIRE ANTENNAS

In the frequency band from 2 to 30 MHz long wires (several wavelengths long) supported by suitable towers may be used as efficient antennas. The best known types are the horizontal V antenna, the horizontal rhombic antenna, the vertical V and sloping rhombic antennas, the vertical inverted V or half rhombic antenna and the single horizontal-wire antenna. Most long wire antennas can be operated as resonant antennas, in which case the current on the wire will be a standing wave with the sinusoidal variation. These antennas usually operate satisfactorily only at a particular frequency and harmonics of this frequency. The input impedance will be highly frequency selective, so only narrow-band

operation is possible. Most long-wire antennas can also be operated as traveling wave or nonresonant structures by terminating the far end of the wire in a suitable resistance having a value equal to the characteristic impedance of the antenna viewed as a transmission line. In this mode of operation the useful frequency band can be quite large, with an acceptable impedance match over the whole range of frequencies.

Various types of long-wire antennas are used for commercial shortwave transmission in the frequency range from 2 to 30 MHz when propagation is by means of ionospheric reflection. For these applications the optimum angle of radiation is usually from 10 to 30° relative to the horizontal line in the direction of receiving station.

Since the long-wire antennas are located in the presence of ground, the latter has an important effect on the radiation pattern and must be taken into account in the design of antenna configuration. In general, the design problem is one of obtaining a directive beam at the desired angle relative to the ground for optimum long-distance communication via reflection from the ionosphere, along with acceptable input impedance characteristics that will facilitate matching the antenna to its feed line.

A monopole antenna consists of one-half of a dipole antenna mounted above the earth or a ground plane. It is normally one-quarter-wavelength long, except with space restrictions or other factors dictate a shorter length. The vertical monopole antenna is used extensively for commercial AM broadcasting (550-1500KHz) in part because it is the shortest efficient antenna to use at these long wavelengths (200 to 600m) and also because vertical polarization suffers less propagation loss than horizontal polarization does at these frequencies. The monopole antenna is also widely used for the land mobile-communication service. Quarter wavelength antennas are widely used in mobile communications with the vehicle itself providing the required ground plane. In the 27-MHz citizen band, a quarter-wavelength monopole antenna is 2.77m long. Many CB band radio users find an antenna of this length undesirable. Consequently antennas for the CB radio are often only 1 to 1.5m long and use either base loading or center loading to tune the antenna to resonance. The overall efficiency will not be as great as for the full-length antenna, since the radiation resistance is reduced quite markedly, and the unavoidable dissipative losses in the tuning coil, ground screen, and the antenna itself will consume a significant fraction of the input power.

Propagation below 2 MHz is made possible by the surface waves for which the horizontally polarized waves are attenuated much more rapidly than vertically polarized fields. For this reason horizontally oriented long wire antennas are normally not used below 2 MHz. In the shortwave band from 2 to 30MHz, where propagation is via ionospheric reflection, long-wire antennas are effective and because of their simple structures are commonly used. Rhombic and V antennas also find some applications at frequencies from 30 to 60 MHz.

At frequencies above about 300MHz slot antennas cut in a metallic surface, such as the skin of an aircraft or the wall of a waveguide often prove to be convenient radiators. The

slot may be fed by a generator or transmission line connected across it or in the case of the waveguide, by a guided wave incident upon the slot.

At very high frequencies (3-30 GHz), the size of the radiating elements become very small. It is then convenient to use the concept of “current sheet radiators” such as slot antennas, horns and paraboloid antennas. The radiation from these kind of current sheet radiators can be evaluated from the individual current elements exactly as we have done for the linear radiators provided the current distribution is known or can be estimated. However, in many cases, the current distribution is neither known nor can be easily estimated. In that case, a method often used to compute the radiated fields due to continuous current distributions is the “aperture” of the antenna.

The discone antenna, the helical antenna are used in the VHF-UHF range. The former is used to radiate an omnidirectional pattern with vertical polarization. It is a broadband antenna with usable characteristics over a frequency range of nearly 10:1. It is usually designed to be fed directly from a 50-Ω coaxial line and is mounted directly on the end of that line. This type of antenna is ideal for base-station operation for urban mobile communication systems, since it gives a good omnidirectional pattern, is physically very compact and rugged, and is quite inexpensive to construct. Its directional gain along the horizontal plane is comparable to that of dipole antenna.

The log periodic antenna is basically an array of dipoles, fed with alternating phase, lined up along the axis of radiation. The element lengths and their spacing all conform to a ratio, given as

$$\tau = \frac{L_{n+1}}{L_n} = \frac{X_{n+1}}{X_n}$$

The angle of divergence is given as

$$\alpha = \tan^{-1} \left( \frac{L_n}{X_n} \right)$$

The open-end length  $L$  must be larger than  $\frac{\lambda}{2}$  if high efficiency is to be obtained. The impedance of this antenna is a periodic function of the logarithm of the frequency-hence its name. The antenna characteristics are broadband and it has the directional characteristics of a dipole array. This type of antenna is often used for mobile-base-station operations, where many channels must be handled over a single antenna system with good directive characteristics.

### 3.5 APERTURE ANTENNAS

The literal meaning of an aperture is an opening or a slot in a closed surface. An aperture antenna therefore, is made out of a closed surface by making a small opening or a slot that is made to carry a time-varying current and hence to radiate. Computation of the fields is not as straightforward as for the simple geometry antennas that we covered previously. The electromagnetic fields in a source free lossless region are completely specified by the tangential components of the electric and the magnetic fields on the surface enclosing the region. As the region is considered to be source free, the tangential

fields on the surface and the fields inside the region are produced by sources external to the region. As we may observe later, the aperture antenna is analyzed by making use of the tangential components of the electric field and the magnetic field. We know that, across the boundary of two media, the tangential components of the electric field  $\mathbf{E}$  and  $\mathbf{H}$ . If the fields in a plane aperture are  $\mathbf{E}_a$  and  $\mathbf{H}_a$ , then

$$\mathbf{J}_S = \hat{n} \times \mathbf{H}_a \text{ and}$$

$$\mathbf{M}_S = -\hat{n} \times \mathbf{E}_a$$

where  $\mathbf{J}_S$  is the surface current density and  $\mathbf{M}_S$  is the magnetic current density. The concept of magnetic current density may sound absurd in the first place as it would require the flow of magnetic charges in a closed path and this is not possible because of the fact that magnetic charges or monopoles do not exist. However, the concept of one would help analyzing the behavior of structures that radiate from apertures. As we have seen previously, the wire currents are suitably excited by high frequency currents to produce radiated fields. However, we cannot apply the same principle to an aperture simply because of the fact that it is an opening or a cavity (shape does not matter now) in an otherwise closed surface and conventional electric current cannot flow in such an opened out structure. We, therefore need a different approach to evaluate the radiated fields due to an aperture like structure made in a metallic surface. This approach makes use of Huygen's secondary wave principle following which the two expressions are written. A large square surface of a plane wave front acts like a rectangular array of Huygen's sources, all fed in phase. The radiation pattern of the array is, therefore, obtained by multiplying the unit pattern of the element by the array factor. The magnetic vector potential is expressed as

$$\mathbf{A}(r, \theta, \phi) = \frac{\mu}{4\pi} \iiint_{V'} \mathbf{J}_S(x', y', z') \frac{\exp(-j\beta R)}{R} dv'$$

We have previously seen from (2.75) that the electric field can also be evaluated in terms of the magnetic vector potential. Combined with the gradient of the scalar potential, we have

$$\mathbf{E} = -j\omega\mathbf{A} - \nabla V = -j\omega\mathbf{A} - \nabla(\nabla \cdot \mathbf{A})$$

$$\mathbf{H} = \frac{1}{\mu} \nabla \times \mathbf{A}$$

Similarly, we may define an electric vector potential due to the magnetic current flow as the following:

$$\mathbf{F}(r, \theta, \phi) = \frac{\varepsilon}{4\pi} \iiint_{V'} \mathbf{M}_S(x', y', z') \frac{\exp(-j\beta R)}{R} dv'$$

Here,  $V'$  is the volume that contains the magnetic source current  $M_S$ . In similar lines, we may write

$$\mathbf{E} = -\frac{1}{\varepsilon} \nabla \times \mathbf{F}$$

Making use of

$$\nabla \times \mathbf{F} = \frac{\partial F_\theta}{\partial r} a_\phi - \frac{\partial F_\phi}{\partial r} a_\theta$$

The electric field in terms of the electric vector potential is expressed as

$$\mathbf{E} = -\frac{1}{\varepsilon} \left( \frac{\partial F_\theta}{\partial r} \mathbf{a}_\phi - \frac{\partial F_\phi}{\partial r} \mathbf{a}_\theta \right)$$

$$\mathbf{E} = -\frac{1}{\varepsilon} \left[ -\frac{j\beta}{r} F_{\theta 0}(r, \theta, \phi) \exp(-j\beta r) \mathbf{a}_\phi + \frac{j\beta}{r} F_{\phi 0}(r, \theta, \phi) \exp(-j\beta r) \mathbf{a}_\theta \right]$$

$$= j \frac{\beta}{\varepsilon} [F_\theta(r, \theta, \phi) \mathbf{a}_\phi - F_\phi(r, \theta, \phi) \mathbf{a}_\theta]$$

$$= j\omega\eta [F_\theta(r, \theta, \phi) \mathbf{a}_\phi - F_\phi(r, \theta, \phi) \mathbf{a}_\theta]$$

and the corresponding magnetic field as

$$\mathbf{H} = -j\omega\mathbf{F} - \nabla(\nabla \cdot \mathbf{F})$$

The total electric field due to the magnetic vector potential, electric vector potential, magnetic scalar potential and electric scalar potential is expressed as

$$\mathbf{E} = -\frac{1}{\varepsilon} \nabla \times \mathbf{F} - j\omega\mathbf{A} - \frac{j}{\omega\mu\varepsilon} \nabla(\nabla \cdot \mathbf{A})$$

and similarly,

$$\mathbf{H} = -\frac{1}{\mu} \nabla \times \mathbf{A} - j\omega\mathbf{F} - \frac{j}{\omega\mu\varepsilon} \nabla(\nabla \cdot \mathbf{F})$$

Now, we can express the radiated field component due to all the factors combined together as

$$\mathbf{E} = j\omega\eta [F_\theta(r, \theta, \phi) \mathbf{a}_\phi - F_\phi(r, \theta, \phi) \mathbf{a}_\theta] - j\omega(A_\theta \mathbf{a}_\theta + A_\phi \mathbf{a}_\phi)$$

Separating the  $\theta$  - and the  $\phi$  - components, we have

$$E_\theta \approx -j\omega[\eta F_\phi(r, \theta, \phi) + A_\theta] \text{ and}$$

$$E_\phi \approx -j\omega[A_\phi - \eta F_\theta(r, \theta, \phi)]$$

The corresponding magnetic fields are expressed as

$$H_\theta \approx -\frac{E_\phi}{\eta}$$

$$H_\phi \approx \frac{E_\theta}{\eta} \quad (\text{B})$$

Next, we wish to evaluate the radiated fields due to a rectangular aperture of size  $(a \times b)$  placed in the  $xy$ -plane and there is an electric field along the  $x$  axis and a magnetic field along the  $y$  - axis. Further, these fields are assumed to be constants over the aperture. Let  $\mathbf{E}_a = E_0 \mathbf{a}_y$  and  $\mathbf{H}_a = -H_0 \mathbf{a}_x$ . The magnetic surface current through the aperture is

$$\mathbf{M}_s = -\hat{n} \times \mathbf{E} = -\mathbf{a}_z \times E_0 \mathbf{a}_y = E_0 \mathbf{a}_x$$

Similarly, the electric current density through the aperture is

$$\mathbf{J}_s = \hat{n} \times \mathbf{H}_a = \mathbf{a}_z \times -H_0 \mathbf{a}_x = -H_0 \mathbf{a}_y$$

The electric vector potential is

$$\begin{aligned}
\mathbf{F}(r, \theta, \phi) &= \frac{\varepsilon}{4\pi} \iiint_{V'} \mathbf{M}_s(x', y', z') \frac{\exp(-j\beta R)}{R} dv' \\
&= \frac{\varepsilon}{4\pi} \iiint_{V'} E_0 a_x \frac{\exp(-j\beta R)}{R} dv' \quad (\text{A}) \\
&= \frac{\varepsilon}{4\pi} E_0 a_x \iiint_{V'} \frac{\exp(-j\beta R)}{R} dx' dy'
\end{aligned}$$

Hence, the integral reduces to computing the exponential term. We find that, a little manipulation of (2.49) results in the following simplified expression for the distant point located  $R$  units away from the origin. Therefore,

$$\begin{aligned}
R &= \left[ (x - x')^2 + (y - y')^2 + (z - z')^2 \right] \\
&= \left[ r^2 + (x'^2 + y'^2) - 2r(x' \sin \theta \cos \phi + y' \sin \theta \sin \phi) \right]^{1/2} \\
&= \left[ r^2 + r'^2 - 2r(x' \sin \theta \cos \phi + y' \sin \theta \sin \phi) \right]^{1/2} \\
&= r \left[ 1 + \left( \frac{r'}{r} \right)^2 - \frac{2}{r} (x' \sin \theta \cos \phi + y' \sin \theta \sin \phi) \right]^{1/2} \\
&\cong r \left[ 1 - \frac{1}{r} (x' \sin \theta \cos \phi + y' \sin \theta \sin \phi) + \frac{1}{2} \left( \frac{r'}{r} \right)^2 + \dots \right] \\
&= r \left[ 1 - \frac{1}{r} (x' \sin \theta \cos \phi + y' \sin \theta \sin \phi) \right]
\end{aligned}$$

Substituting this in (A), we have

$$\begin{aligned}
\mathbf{F}(r, \theta, \phi) &= \frac{\varepsilon}{4\pi} E_0 a_x \iiint_S \frac{\exp(-j\beta R)}{R} dx' dy' \\
&= \frac{\varepsilon}{4\pi r} E_0 a_x \iiint_S \exp(-j\beta [r - x' \sin \theta \cos \phi - y' \sin \theta \sin \phi]) dx' dy' \\
&= -\frac{\varepsilon E_0}{4\pi r} \exp(-j\beta r) \iiint_S \exp(j\beta x' \sin \theta \cos \phi + y' \sin \theta \sin \phi) dx' dy' \\
&= \varepsilon E_0 G I
\end{aligned}$$

where  $I$  represents the integral over the aperture surface and  $G$  is the familiar scalar spherical wave function given as

$$G = \frac{\exp(-j\beta r)}{4\pi r}$$

The integral  $I$  is evaluated as

$$\begin{aligned}
& \int_{-a/2}^{a/2} \exp(j\beta x' \sin \theta \cos \phi) dx' \\
&= \frac{1}{j\beta \sin \theta \cos \phi} \exp(j\beta x' \sin \theta \cos \phi) \Big|_{-a/2}^{a/2} \\
&= \frac{1}{j\beta \sin \theta \cos \phi} \left[ \exp\left(j\beta \frac{a}{2} \sin \theta \cos \phi\right) - \exp\left(-j\beta \frac{a}{2} \sin \theta \cos \phi\right) \right] \\
&= \frac{2j \sin\left(\beta \frac{a}{2} \sin \theta \cos \phi\right)}{j\beta \sin \theta \cos \phi} = \frac{a \sin\left(\beta \frac{a}{2} \sin \theta \cos \phi\right)}{(a/2)\beta \sin \theta \cos \phi} \\
&= a \operatorname{sinc}\left(\beta \frac{a}{2} \sin \theta \cos \phi\right)
\end{aligned}$$

Therefore,

$$\begin{aligned}
& \iiint_S \exp(j\beta x' \sin \theta \cos \phi + y' \sin \theta \sin \phi) dx' dy' \\
&= ab Sa\left(\frac{\beta a}{2} \sin \theta \cos \phi\right) Sa\left(\frac{\beta b}{2} \sin \theta \sin \phi\right)
\end{aligned}$$

where  $Sa(x) = \frac{\sin x}{x}$ . The electric vector potential has a component along the  $x$ -axis only. In a similar manner, we can evaluate the magnetic vector potential also by writing the following:

$$\begin{aligned}
\mathbf{A}(r, \theta, \phi) &= \frac{\mu}{4\pi} \iiint_{V'} \mathbf{J}_s(x', y', z') \frac{\exp(-j\beta R)}{R} dv' \\
&= \frac{\mu}{4\pi} \iiint_{V'} -H_0 a_y \frac{\exp(-j\beta R)}{R} dv' \\
&= \frac{\mu}{4\pi} \cdot -H_0 a_y \iiint_S \frac{\exp(-j\beta R)}{R} dx' dy'
\end{aligned}$$

This turns out to be

$$\begin{aligned}
\mathbf{A}(r, \theta, \phi) &= \frac{\mu}{4\pi} \cdot -H_0 a_y \iiint_S \frac{\exp(-j\beta R)}{R} dx' dy' \\
&= -\mu H_0 G I
\end{aligned}$$

We know from elementary coordinate geometry that

$$A_\theta = A_x \cos \theta \cos \phi, \quad A_\phi = -A_x \sin \phi \quad \text{and}$$

$$F_\theta = F_y \cos \theta \sin \phi, \quad F_\phi = F_y \cos \phi$$

From all these above discussions, it is clear that the magnetic vector potential has component along the  $y$ -axis only. We now combine these two results and write the overall radiated fields as

Therefore,

$$\begin{aligned}
E_\theta &= -j\omega[\eta F_\phi(r, \theta, \phi) + A_\theta] \\
&= -j\omega[-\eta F_x \sin \phi + A_y \cos \theta \sin \phi] \\
&= -j\omega[-\eta \varepsilon E_0 GI \sin \phi - \mu H_0 GI \cos \theta \sin \phi] \\
&= j\omega ab G(\eta \varepsilon E_0 + \mu H_0 \cos \theta) \sin \phi Sa\left(\frac{\beta a}{2} \sin \theta \cos \phi\right) Sa\left(\frac{\beta b}{2} \sin \theta \sin \phi\right) \\
&= j\omega ab GE_0 \left(\eta \varepsilon + \frac{\mu}{\eta} \cos \theta\right) \sin \phi Sa\left(\frac{\beta a}{2} \sin \theta \cos \phi\right) Sa\left(\frac{\beta b}{2} \sin \theta \sin \phi\right)
\end{aligned}$$

This is due to the fact that  $\mu H_0 = \frac{\mu}{\eta} E_0$  and  $\eta \varepsilon = \sqrt{\frac{\mu}{\varepsilon}} \cdot \varepsilon = \sqrt{\mu \varepsilon} = \frac{1}{c}$  and

$\frac{\mu}{\eta} = \mu \cdot \sqrt{\frac{\varepsilon}{\mu}} = \sqrt{\mu \varepsilon} = \frac{1}{c}$  and further,  $\frac{\omega}{c} = \frac{2\pi}{\lambda} = \beta$ . This is equal to, after the substitution

of the necessary expressions that

$$\begin{aligned}
E_\theta &= j\omega ab GE_0 (\eta \varepsilon + \cos \theta) \sin \phi Sa\left(\frac{\beta a}{2} \sin \theta \cos \phi\right) Sa\left(\frac{\beta b}{2} \sin \theta \sin \phi\right) \\
&= j\beta ab E_0 (1 + \cos \theta) \sin \phi Sa\left(\frac{\beta a}{2} \sin \theta \cos \phi\right) Sa\left(\frac{\beta b}{2} \sin \theta \sin \phi\right)
\end{aligned}$$

Similarly,

$$\begin{aligned}
E_\phi &\approx -j\omega[A_\phi - \eta F_\theta(r, \theta, \phi) -] \\
&= -j\omega[A_y \cos \phi - \eta F_x \cos \theta \cos \phi] \\
&= -j\omega[-\mu H_0 GI \cos \phi - \eta \varepsilon E_0 GI \cos \theta \cos \phi] \\
&= j\omega G(\mu H_0 + \eta \varepsilon E_0 \cos \theta) \cos \phi Sa\left(\frac{\beta a}{2} \sin \theta \cos \phi\right) Sa\left(\frac{\beta b}{2} \sin \theta \sin \phi\right) \\
&= j\beta Gab E_0 (1 + \cos \theta) \cos \phi Sa\left(\frac{\beta a}{2} \sin \theta \cos \phi\right) Sa\left(\frac{\beta b}{2} \sin \theta \sin \phi\right)
\end{aligned}$$

From the expressions for the electric field in the  $\theta - \phi$  plane, we observe that the maximum value of  $Sa(x)$  is obtained for  $x = 0$ . This corresponds to the case of  $\theta = 0$ . The associated magnetic fields are given as (B). In the far field region, the radiation intensity is  $r^2$  times the time-averaged power density and this is expressed as

$$U(\theta, \phi) = \frac{r^2}{2\eta} \left[ |E_\theta|^2 + |E_\phi|^2 \right] \text{ ©}$$

Substitution of the necessary expressions in © gives us

$$\begin{aligned}
U(\theta, \phi) &= \frac{r^2}{2\eta} \left[ |E_\theta|^2 + |E_\phi|^2 \right] \\
&= \frac{\beta^2}{2\eta(4\pi)^2} (ab)^2 |E_0|^2 (1 + \cos \theta)^2 Sa^2\left(\frac{\beta a}{2} \sin \theta \cos \phi\right) Sa^2\left(\frac{\beta b}{2} \sin \theta \sin \phi\right) \quad \text{(D)}
\end{aligned}$$



Therefore, the maximum radiation intensity is obtained by substituting  $\theta = 0$  in (D) and hence we obtain

$$\begin{aligned}
 U(\theta, \phi) &= \frac{r^2}{2\eta} \left[ |E_\theta|^2 + |E_\phi|^2 \right] \\
 &= \frac{\beta^2}{2\eta(4\pi)^2} (ab)^2 |E_0|^2 (1 + \cos \theta)^2 Sa^2 \left( \frac{\beta a}{2} \sin \theta \cos \phi \right) Sa^2 \left( \frac{\beta b}{2} \sin \theta \sin \phi \right) \\
 &= \beta^2 \frac{(ab)^2 |E_0|^2}{2\eta(4\pi)^2} \cdot 4 \\
 &= \frac{|E_0|^2}{2\eta} \left( \frac{2\pi}{\lambda} \right)^2 \left( \frac{ab}{2\pi} \right)^2 \\
 &= \frac{|E_0|^2}{2\eta} \left( \frac{ab}{\lambda} \right)^2
 \end{aligned}$$

The radiated power passing through the aperture area is found out by evaluating the Poynting vector and integrating it over the aperture. Doing this, we obtain

$$\int_{\Omega} U(\theta, \phi) d\Omega = \oint_S (\mathbf{E}_a \times \mathbf{H}_a) \cdot d\mathbf{s}$$

As  $\mathbf{E}_a = E_0 a_y$  and  $\mathbf{H}_a = -H_0 a_x$ , the power radiated through the aperture becomes

$$\begin{aligned}
 \frac{1}{2} \oint_S (\mathbf{E}_a \times \mathbf{H}_a) \cdot d\mathbf{s} &= \frac{1}{2} \oint_S (E_0 a_y \times -H_0 a_x) \cdot d\mathbf{s} \\
 &= \frac{1}{2} |E_0| \cdot \frac{|E_0|}{\eta} ab = \frac{ab}{2\eta} |E_0|^2
 \end{aligned}$$

The directivity reduces to

$$D_{\max} = \frac{4\pi \left( \frac{ab}{\lambda} \right)^2 |E_0|^2}{ab \frac{|E_0|^2}{2\eta}} = 4\pi \left( \frac{ab}{\lambda} \right)^2$$

The expression for directivity shows that ratio of the directivity to the aperture area is a constant which is equal to  $\left( \frac{4\pi}{\lambda} \right)^2$  and is independent of the antenna size. This depends

only on the wavelength or frequency of operation. Less the wavelength, higher is the value. However, if the current distribution is not uniform, then an equivalent uniform aperture area is defined as the maximum effective aperture area and then the expression for directivity gets modified as

$$D_{\max} = \frac{4\pi}{\lambda^2} A_e$$

where  $A_e$  is the effective aperture area. For a uniform current distribution, the effective area is the same as that of the actual area of the aperture.

### 3.6 Rectangular Waveguides

A rectangular waveguide is used to carry energy from a source to a destination at microwave and optical frequencies. This is a hollow metallic pipe with a rectangular cross section. It is assumed that the walls of the waveguide have infinite conductivity and the medium filling up the space is an ideal dielectric with a given permeability, permittivity and no conductivity. The waveguide is assumed to have a rectangular cross section of dimension  $a \times b$  and is infinitely long. We may assume here that  $a \geq b$  and the broader dimension;  $a$  is oriented along the  $x$ -axis and the shorter dimension  $b$  is aligned along the  $y$ -axis. The length of the waveguide is aligned along the  $z$ -axis. We further assume wave propagation to take place along the positive  $z$ -axis.

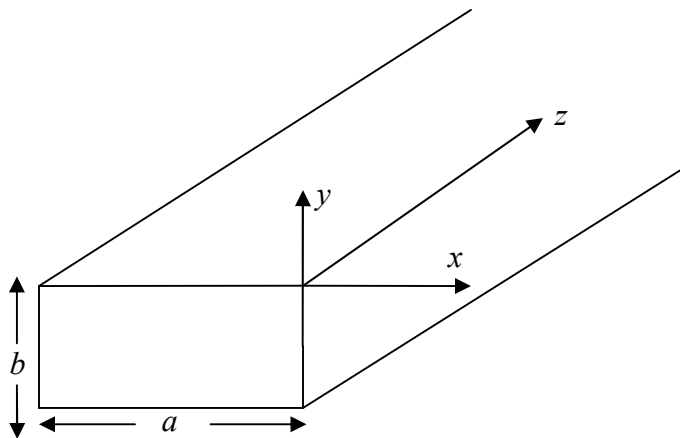

A hollow rectangular waveguide with dimension  $a \times b$

We may note that the wave propagation inside a hollow structure such as the one shown in Fig. takes place in the form of modes. It is no longer the uniform plane waves or the TEM mode that is possible in an unbounded homogeneous medium. As we may see, the walls of the waveguide are made of a good conductor while the hollow space is filled with some kind of dielectric. Hence, any wave propagating inside the space has to be governed by boundary conditions along the two dimensions;  $x$ - and the  $y$ -axes. As we shall see, application of the boundary conditions at the cross section gives rise to modes for the waves. A mode is characterized by an integer number of half sinusoids along the particular dimension under consideration. The simplest being just half a sinusoid typically known as the dominant mode. The waves have to be transverse electric (TE), transverse magnetic <sup>TM</sup> waves or some definite combination of these two known as hybrid modes. As we know, the longitudinal electric field is zero while there exists a nonzero longitudinal magnetic field for the TE waves. Let us analyze the TE waves first.

## Transverse Electric (TE) Waves

As the magnetic field has a nonzero component along the  $z$ -axis, the wave equation becomes

$$\nabla^2 H_z + \omega^2 \mu \epsilon H_z = 0$$

Expansion of this gives us

$$\left( \frac{\partial^2}{\partial x^2} + \frac{\partial^2}{\partial y^2} + \frac{\partial^2}{\partial z^2} \right) H_z + \omega^2 \mu \epsilon H_z = 0$$

Let  $H_z(x, y, z, t) = X(x)Y(y)Z(z)\exp(j\omega t)$

Performing the double differentiation, we obtain

$$YZ \frac{d^2 X}{dx^2} + ZX \frac{d^2 Y}{dy^2} + XY \frac{d^2 Z}{dz^2} + \omega^2 \mu \epsilon XYZ = 0$$
$$\Rightarrow \frac{1}{X} \frac{d^2 X}{dx^2} + \frac{1}{Y} \frac{d^2 Y}{dy^2} + \frac{1}{Z} \frac{d^2 Z}{dz^2} + \omega^2 \mu \epsilon = 0$$

Dividing both sides by  $XYZ$

Now, we can equate each of these terms to a constant as shown below

$$\frac{1}{X} \frac{d^2 X}{dx^2} = -A^2, \quad \frac{1}{Y} \frac{d^2 Y}{dy^2} = -B^2 \quad \text{and} \quad \frac{1}{Z} \frac{d^2 Z}{dz^2} = -\beta^2$$

The differential equation becomes

$$\frac{1}{X} \frac{d^2 X}{dx^2} + \frac{1}{Y} \frac{d^2 Y}{dy^2} - \beta^2 + \omega^2 \mu \epsilon = 0$$
$$\Rightarrow -A^2 - B^2 + h^2 = 0$$
$$\Rightarrow h^2 = A^2 + B^2$$

In the above equation, we have made use of

$$\omega^2 \mu \epsilon - \beta^2 = h^2$$

We have, therefore

$$\frac{d^2 X}{dx^2} = -A^2 X$$

$$\Rightarrow X = C_1 \sin Ax + C_2 \cos Ax$$

Similarly,

$$\frac{d^2 Y}{dy^2} = -B^2 Y$$

$$\Rightarrow Y = C_3 \sin By + C_4 \cos By$$

The complete solution of the longitudinal magnetic field, therefore becomes

$$H_z(x, y, z, t) = (C_1 \sin Ax + C_2 \cos Ax)(C_3 \sin By + C_4 \cos By)\exp(-j\beta z)\exp(j\omega t)$$

We know that the tangential electric fields are  $E_x$  and  $E_y$  which are related to the magnetic field  $H_z$  in the following manner:

$$E_x = -\frac{j\omega\mu}{h^2} \frac{\partial H_z}{\partial y}$$

$$\Rightarrow E_x = -\frac{j\omega\mu}{h^2} (C_1 \sin Ax + C_2 \cos Ax)(C_3 B \cos By - C_4 B \sin By) \exp(-j\beta z) \exp(j\omega t)$$

And similarly,

$$E_y = \frac{j\omega\mu}{h^2} \frac{\partial H_z}{\partial x}$$

$$\Rightarrow E_y = \frac{j\omega\mu}{h^2} (C_1 A \cos Ax - C_2 A \sin Ax)(C_3 \sin By + C_4 \cos By) \exp(-j\beta z) \exp(j\omega t)$$

The waveguide walls are metallic surfaces bounded by  $x = 0$  to  $x = a$  on the broader side and  $y = 0$  to  $y = b$  on the narrower side. The tangential components of the electric fields are zero at the walls. Therefore, both  $E_x$  and  $E_y$  are zero, however, at different surfaces.

The  $E_x$  field is zero at  $y = 0$  and  $y = b$  while the  $E_y$  is zero at  $x = 0$  and  $x = a$ ,

Substituting these into the two tangential electric fields, we have  $C_3 = 0$  obtained for  $E_x$  and  $C_1 = 0$  for  $E_y$ . Similarly, at the ends of the cross section, we get

$$E_x = -\frac{j\omega\mu}{h^2} (C_1 \sin Ax + C_2 \cos Ax)(-C_4 B \sin Bb) \exp(-j\beta z) \exp(j\omega t) = 0$$

$$\Rightarrow B = \frac{n\pi}{b}$$

Similarly,

$$E_y = \frac{j\omega\mu}{h^2} (-C_2 A \sin Ax)(C_3 \sin By + C_4 \cos By) \exp(-j\beta z) \exp(j\omega t) = 0$$

$$\Rightarrow A = \frac{m\pi}{a}$$

The resultant solution, therefore becomes

$$\begin{aligned} E_x &= \frac{j\omega\mu}{h^2} \left( \frac{n\pi}{b} \right) \left( C_2 \cos \frac{m\pi}{a} x \right) \left( C_4 B \sin \frac{n\pi}{b} y \right) \exp(-j\beta z) \exp(j\omega t) \\ &= \frac{j\omega\mu}{h^2} K \left( \frac{n\pi}{b} \right) \left( \cos \frac{m\pi}{a} x \right) \left( \sin \frac{n\pi}{b} y \right) \exp(-j\beta z) \exp(j\omega t) \end{aligned}$$

We have expressed  $C_2 C_4 = K$

Similarly,

$$\begin{aligned} E_y &= \frac{j\omega\mu}{h^2} \left( \frac{m\pi}{a} \right) \left( -C_2 A \sin \frac{m\pi}{a} x \right) \left( C_4 \cos \frac{n\pi}{b} y \right) \exp(-j\beta z) \exp(j\omega t) \\ &= -\frac{j\omega\mu}{h^2} \left( \frac{m\pi}{a} \right) K \left( \sin \frac{m\pi}{a} x \right) \left( \cos \frac{n\pi}{b} y \right) \exp(-j\beta z) \exp(j\omega t) \end{aligned}$$

The tangential magnetic fields are expressed as

$$\begin{aligned}
H_x &= \frac{j\omega\varepsilon}{h^2} \frac{\partial E_z}{\partial y} - \frac{j\beta}{h^2} \frac{\partial H_z}{\partial x} \\
&= -\frac{j\beta}{h^2} \left(\frac{m\pi}{a}\right) K \left(\sin \frac{m\pi}{a} x\right) \left(-\cos \frac{n\pi}{b} y\right) \exp(-j\beta z) \exp(j\omega t) \quad \ominus E_z = 0 \\
&= \frac{j\beta}{h^2} \left(\frac{m\pi}{a}\right) K \left(\sin \frac{m\pi}{a} x\right) \left(\cos \frac{n\pi}{b} y\right) \exp(-j\beta z) \exp(j\omega t)
\end{aligned}$$

$$\begin{aligned}
H_y &= -\frac{j\omega\varepsilon}{h^2} \frac{\partial E_z}{\partial x} - \frac{j\beta}{h^2} \frac{\partial H_z}{\partial y} \\
&= \frac{j\beta}{h^2} K \left(\frac{n\pi}{b}\right) \left(\cos \frac{m\pi}{a} x\right) \left(\sin \frac{n\pi}{b} y\right) \exp(-j\beta z) \exp(j\omega t) \quad \ominus E_z = 0
\end{aligned}$$

and finally,

$$\begin{aligned}
H_z(x, y, z, t) &= \left(C_2 \cos \frac{m\pi}{a} x\right) \left(C_4 \cos \frac{n\pi}{b} y\right) \exp(-j\beta z) \exp(j\omega t) \\
&= K \cos\left(\frac{m\pi}{a} x\right) \cos\left(\frac{n\pi}{b} y\right) \exp(-j\beta z) \exp(j\omega t)
\end{aligned}$$

We may further verify that,

$$h^2 = \omega^2 \mu \varepsilon - \beta^2 =$$

$$A^2 + B^2 = \left(\frac{m\pi}{a}\right)^2 + \left(\frac{n\pi}{b}\right)^2$$

The integers  $m$  and  $n$  together define the order of the mode the wave takes on to propagate down the walls of the waveguide. The mode is designated as  $TE_{mn}$  mode. We observe from the expressions for the transverse fields that, either of the integers may be zero for these to be nonzero as each of the four fields contain a half cosine term given by  $\cos\left(\frac{m\pi}{a} x\right)$  or  $\cos\left(\frac{n\pi}{b} y\right)$ . If both of the integers are zero, then the longitudinal magnetic field  $H_z$  becomes non zero, however, all the transverse fields become zero. As we know, a magnetic field variation in space is not possible without a corresponding electric field and vice versa. Thus, there can be no  $TE_{00}$  mode. We can have, as the lowest order modes corresponding to either  $m = 0$  giving rise to  $TE_{01}$  mode or a  $TE_{10}$  mode corresponding to  $n = 0$ .

Prob: Establish the field relations from the four basic Maxwell's equations.

Prob: Establish the dimensional of  $h^2$ . What is its significance?

Prob: Sketch  $\cos\left(\frac{m\pi}{a} x\right)$  and  $\sin\left(\frac{n\pi}{b} y\right)$  mark your observations.

## Transverse Magnetic (TM) Waves

Similar to the TE waves, the TM waves are characterized by a longitudinal electric field;  $E_z \neq 0$  and the magnetic field  $H_z = 0$ . Therefore, the equation governing the TM mode is expressed as

$$\nabla^2 E_z + \omega^2 \mu \epsilon E_z = 0$$

Expansion of this gives us

$$\left( \frac{\partial^2}{\partial x^2} + \frac{\partial^2}{\partial y^2} + \frac{\partial^2}{\partial z^2} \right) E_z + \omega^2 \mu \epsilon E_z = 0$$

Let  $E_z(x, y, z, t) = X(x)Y(y)Z(z)\exp(j\omega t)$

Performing the double differentiation, we obtain

$$YZ \frac{d^2 X}{dx^2} + ZX \frac{d^2 Y}{dy^2} + XY \frac{d^2 Z}{dz^2} + \omega^2 \mu \epsilon XYZ = 0$$

$$\Rightarrow \frac{1}{X} \frac{d^2 X}{dx^2} + \frac{1}{Y} \frac{d^2 Y}{dy^2} + \frac{1}{Z} \frac{d^2 Z}{dz^2} + \omega^2 \mu \epsilon = 0$$

Dividing both sides by  $XYZ$

Now, we can equate each of these terms to a constant as shown below

$$\frac{1}{X} \frac{d^2 X}{dx^2} = -A^2, \quad \frac{1}{Y} \frac{d^2 Y}{dy^2} = -B^2 \quad \text{and} \quad \frac{1}{Z} \frac{d^2 Z}{dz^2} = -\beta^2$$

The differential equation becomes

$$\frac{1}{X} \frac{d^2 X}{dx^2} + \frac{1}{Y} \frac{d^2 Y}{dy^2} - \beta^2 + \omega^2 \mu \epsilon = 0$$

$$\Rightarrow -A^2 - B^2 + h^2 = 0$$

In the above equation, we have made use of

$$\omega^2 \mu \epsilon - \beta^2 = h^2$$

We have, therefore

$$\frac{d^2 X}{dx^2} = -A^2 X$$

$$\Rightarrow X = C_1 \sin Ax + C_2 \cos Ax$$

Similarly,

$$\frac{d^2 Y}{dy^2} = -B^2 Y$$

$$\Rightarrow Y = C_3 \sin By + C_4 \cos By$$

The complete solution of the longitudinal electric field, therefore becomes

$$E_z(x, y, z, t) = (C_1 \sin Ax + C_2 \cos Ax)(C_3 \sin By + C_4 \cos By)\exp(-j\beta z)\exp(j\omega t) \quad (\text{A})$$

The  $E_z$  field is a tangential field along the  $z$ -axis which is assumed to be infinite in extent. Also, we note that

$$E_z = 0 \quad \text{at} \quad x = 0 \quad \text{and} \quad x = a \quad \text{and likewise} \quad E_z = 0 \quad \text{at} \quad y = 0 \quad \text{and} \quad y = b$$

Substitution of these in (A) gives us  $C_2 = 0$  and further,  $C_4 = 0$ . Again, we have

$A = \frac{m\pi}{a}$  and  $B = \frac{n\pi}{b}$  at the other ends of the rectangular wall.

The complete solution to the longitudinal field then is,

$$\begin{aligned} E_z(x, y, z, t) &= C_1 \sin\left(\frac{m\pi}{a}x\right) C_3 \sin\left(\frac{n\pi}{b}y\right) \exp(-j\beta z) \exp(j\omega t) \\ &= K \sin\left(\frac{m\pi}{a}x\right) \sin\left(\frac{n\pi}{b}y\right) \exp(-j\beta z) \exp(j\omega t) \end{aligned}$$

In the above, we have expressed  $C_1 C_3 = K$

The other transverse fields are obtained as follows:

$$\begin{aligned} E_x &= -\frac{j\beta}{h^2} \frac{\partial E_z}{\partial x} \\ \Rightarrow E_x &= -\frac{j\beta}{h^2} \left(\frac{m\pi}{a}\right) K \cos\left(\frac{m\pi}{a}x\right) \sin\left(\frac{n\pi}{b}y\right) \exp(-j\beta z) \exp(j\omega t) \end{aligned}$$

$$\begin{aligned} E_y &= -\frac{j\beta}{h^2} \frac{\partial E_z}{\partial y} \\ \Rightarrow E_y &= -\frac{j\beta}{h^2} \left(\frac{n\pi}{b}\right) K \sin\left(\frac{m\pi}{a}x\right) \cos\left(\frac{n\pi}{b}y\right) \exp(-j\beta z) \exp(j\omega t) \end{aligned}$$

$$\begin{aligned} H_x &= \frac{j\omega\epsilon}{h^2} \frac{\partial E_z}{\partial y} \\ \Rightarrow H_x &= \frac{j\omega\epsilon}{h^2} \left(\frac{n\pi}{b}\right) K \sin\left(\frac{m\pi}{a}x\right) \cos\left(\frac{n\pi}{b}y\right) \exp(-j\beta z) \exp(j\omega t) \end{aligned}$$

$$\begin{aligned} H_y &= -\frac{j\omega\epsilon}{h^2} \frac{\partial E_z}{\partial x} \\ \text{and,} \\ \Rightarrow E_x &= -\frac{j\omega\epsilon}{h^2} \left(\frac{m\pi}{a}\right) K \cos\left(\frac{m\pi}{a}x\right) \sin\left(\frac{n\pi}{b}y\right) \exp(-j\beta z) \exp(j\omega t) \end{aligned}$$

As before, we note that

$$h^2 = \omega^2 \omega\epsilon - \beta^2 = A^2 + B^2 = \left(\frac{m\pi}{a}\right)^2 + \left(\frac{n\pi}{b}\right)^2$$

The integers  $m$  and  $n$  together define the order of the mode the wave takes on to propagate down the walls of the waveguide. The mode is designated as  $TM_{mn}$  mode. We observe from the expressions for the transverse fields that, if either of the integers is zero, then the fields become zero as each of the four fields contain a half sine term given by  $\cos\left(\frac{m\pi}{a}x\right)$  or  $\cos\left(\frac{n\pi}{b}y\right)$ . Thus, there can be no  $TM_{00}$  mode. Similarly, as the lowest order modes corresponding to either  $m=0$  giving rise to  $TM_{01}$  mode or a  $TM_{10}$  mode corresponding to  $n=0$  are also not possible. The lowest order mode, therefore is attained only when both the integers are at least equal to one,  $m=1=n$ . This is the lowest order or the fundamental mode of a TM wave known as  $TM_{11}$  mode.

## MODULE-IV

**Exercise:** Enumerate the fundamental differences between a TE wave and a TM wave.

We observe from all the above discussions that for both the waves, fields exist in discrete patterns of half sinusoids or cosinusoids corresponding to only integer values of  $m$  and  $n$ . Therefore,  $m$  and  $n$  can take on only discrete values and not a continuum of values. This makes the field pattern for each of the sets of  $m$  and  $n$  unique and also the fundamental mode of propagation. We can also see that, for the guided waves, other than the fundamental mode, all other modes if allowed to exist, are the higher order modes. This essentially means an integer number of half cycles contained along the appropriate dimension. For example, if a mode is given as  $TE_{22}$ , it simply means that there is one full cycle of field variation (two half cycles of alternating polarity) each along the  $x$ -axis and the  $y$ -axis.

At this point, we would like to find out which modes can be supported by a given waveguide. In order to answer that, we note that

$$\beta^2 = \omega^2 \mu \epsilon - \left( \frac{m\pi}{a} \right)^2 - \left( \frac{n\pi}{b} \right)^2$$

Therefore,

$$\beta = \sqrt{\omega^2 \mu \epsilon - \left( \frac{m\pi}{a} \right)^2 - \left( \frac{n\pi}{b} \right)^2}$$

We note that, the  $\omega^2 \mu \epsilon > \left( \frac{m\pi}{a} \right)^2 + \left( \frac{n\pi}{b} \right)^2$  in order for  $\beta$  to be real. And for a give mode to exist in the waveguide, the value of  $\beta$  must be real. The frequency at which  $\beta$  changes from real to imaginary is known as the cut off frequency, given as

$$\omega_c = \frac{1}{\sqrt{\mu \epsilon}} \sqrt{\left[ \left( \frac{m\pi}{a} \right)^2 + \left( \frac{n\pi}{b} \right)^2 \right]} \quad (D)$$
$$\Rightarrow f_c = \frac{1}{2\pi \sqrt{\mu \epsilon}} \sqrt{\left[ \left( \frac{m\pi}{a} \right)^2 + \left( \frac{n\pi}{b} \right)^2 \right]}$$

It follows from (D) that, the fundamental mode for a TE wave has the following cut off frequencies corresponding to  $TE_{10}$  as

$$f_c(TE_{10}) = \frac{1}{2\pi \sqrt{\mu \epsilon}} \left( \frac{\pi}{a} \right) = \frac{1}{2a \sqrt{\mu \epsilon}}$$

Similarly,

$$f_c(TE_{01}) = \frac{1}{2\pi \sqrt{\mu \epsilon}} \left( \frac{\pi}{b} \right) = \frac{1}{2b \sqrt{\mu \epsilon}}$$

And for the TM wave, the fundamental mode has a cut off frequency given as



$$f_c(TM_{11}) = \frac{1}{2\pi\sqrt{\mu\varepsilon}} \sqrt{\left[\left(\frac{\pi}{a}\right)^2 + \left(\frac{\pi}{b}\right)^2\right]}$$

$$= \frac{1}{2\sqrt{\mu\varepsilon}} \sqrt{\left[\left(\frac{1}{a}\right)^2 + \left(\frac{1}{b}\right)^2\right]}$$

As  $a > b$ , therefore, we have

$$f_c(TE_{10}) < f_c(TE_{01}) < f_c(TM_{11})$$

We, therefore see that the lowest frequency that can propagate inside a rectangular waveguide corresponds to the  $TE_{10}$  mode. No power transfer is possible corresponding to a frequency lower than the cutoff frequency. This is simply due to the fact that at frequencies lower than the cut off frequency, the propagation constant  $\beta$  becomes imaginary. Thus, the term  $\exp(-j\beta z) = \exp(\beta z)$  does not represent a wave. In this aspect then, a waveguide can be thought of as a high pass filter allowing frequencies above the cut off frequency. We can further see that, as the order of the mode increases, the cutoff frequency similarly increases. The  $TE_{10}$  is known as the dominant mode of a rectangular waveguide.

Similar to the cutoff frequency, the cut off wavelength for a given mode is given as

$$\lambda_c = \frac{v}{f_c} = \frac{v}{\frac{v}{2\pi} \sqrt{\left[\left(\frac{m\pi}{a}\right)^2 + \left(\frac{n\pi}{b}\right)^2\right]}} = \frac{2}{\sqrt{\left[\left(\frac{m}{a}\right)^2 + \left(\frac{n}{b}\right)^2\right]}}$$

This is due to the fact that the intrinsic velocity of a wave in a waveguide is given as

$$v = \frac{1}{\sqrt{\mu\varepsilon}}.$$

It follows from the above discussion that, the cutoff wavelength corresponding to the dominant  $TE_{10}$  mode is

$$\lambda_c(TE_{10}) = \frac{2}{\sqrt{\left[\left(\frac{1}{a}\right)^2\right]}} = 2a$$

$$\Rightarrow a = \frac{\lambda_c(TE_{10})}{2}$$

The longest wavelength that can propagate inside a rectangular waveguide corresponds to the dominant mode and is equal to twice the size of its broader dimension.

## The Biconical Antenna

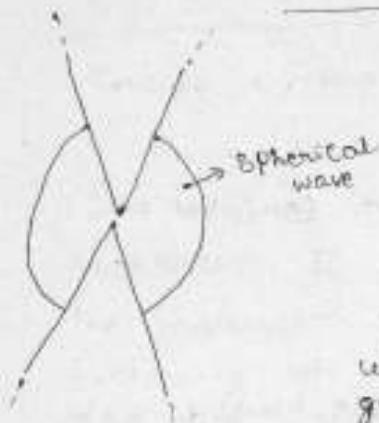

This antenna has broadband characteristics. It is analogous to an infinite uniform transmission line. It acts as a guide for a spherical wave in the same way that a uniform transmission line acts as a guide for a plane wave.

We proceed now to derive the characteristic impedance of this antenna. Let a generator be connected to the terminals of an infinite biconical antenna. The generator causes waves with spherical phase fronts to travel radially outward from the terminals. The waves produce currents on the cones and a voltage between them. Let  $V$  be the voltage between points on the upper and lower cones a distance  $r$  from the terminals. Let  $I$  be the total current on the surface of one of the cones at a distance  $r$  from the terminal.

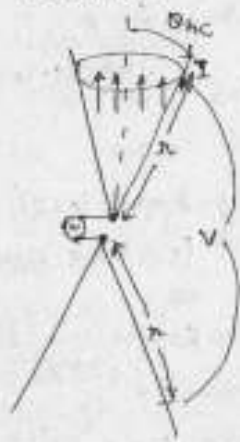

As on an ordinary transmission line, the ratio  $\frac{V}{I}$  is the characteristic impedance of the antenna. For the characteristic impedance to be uniform, it is necessary that the ratio  $\frac{V}{I}$  be independent of  $r$ .

Before  $V$  and  $I$  can be calculated we must determine the nature of the electric and magnetic fields existing in the space between the conducting cones.

Although the biconical transmission line can support an infinite number of transmission

transmission mode is present for the TEM mode, both E and H are entirely transverse they have no radial component. The E lines are along great circles passing through the polar axis. This satisfies the boundary conditions since E is normal to the surface of the cone. The H lines are circles lying in plane normal to the polar axis.

Maxwell's equation from Faraday's law for harmonic varying fields is

$$\nabla \times E = -j\omega\mu H \quad (1)$$

Expanding (1) in spherical coordinates we have

$$\nabla \times E = \frac{a_\theta}{r \sin\theta} \left[ \frac{\partial(\lambda \sin\theta E_\phi)}{\partial\theta} - \frac{\partial(\lambda E_\theta)}{\partial\phi} \right] + \frac{a_\phi}{\lambda \sin\theta} \left[ \frac{\partial E_\theta}{\partial\phi} - \frac{\partial(\lambda \sin\theta E_\phi)}{\partial\lambda} \right] + \frac{a_r}{r} \left[ \frac{\partial(\lambda E_\theta)}{\partial\lambda} - \frac{\partial E_\theta}{\partial\theta} \right] \quad (2)$$

E has only a  $\theta$  component, which by symmetry is independent of  $\phi$ , only the fifth term of (2) does not vanish. Thus,

$$\nabla \times E = \frac{a_\phi}{r} \frac{\partial(\lambda E_\theta)}{\partial\lambda} \quad (3)$$

Expanding the right side of (1) in spherical coordinates,

$$-j\omega\mu H = -j\omega\mu (H_\theta a_\theta + H_\phi a_\phi + H_r a_r) \quad (4)$$

Since H has only a  $\phi$  component, (4) becomes

$$-j\omega\mu H = -j\omega\mu H \cos\theta \dots (5)$$

Now equating (3) and (5) we have

$$\frac{1}{x} \frac{\partial(x\epsilon_0)}{\partial x} = j\omega\mu H \dots (6)$$

Maxwell's equation from Ampere's law for harmonically varying fields in a nonconducting medium is

$$\nabla \times H = j\omega\epsilon E \dots (7)$$

It has only a  $\phi$  component and only a  $\theta$  component. Since  $E_x = 0$  it follows that

$$\frac{\partial(\sin\theta H_\phi)}{\partial \theta} = 0 \dots (8)$$

which when reduced becomes

$$\frac{\partial(\sin\theta H_\phi)}{\partial x} = -j\omega\epsilon(x\epsilon_0) \dots (9)$$

Now differentiating (9) w.r.t.  $x$  and introducing (6), we obtain a wave equation in  $(x, H_\phi)$ . Thus

$$\frac{\partial^2(x H_\phi)}{\partial x^2} = -\omega^2\mu\epsilon(x H_\phi) \dots (10)$$

The condition of (8) requires that  $H_\phi$  vary inversely as the sine of  $\theta$ .

$$H_\phi \propto \frac{1}{\sin\theta}$$

Hence, a solution of (10) which also fulfills (11) is

$$H_\phi = \frac{1}{x \sin\theta} H_0 e^{-j\beta x}$$

$$\text{where } \beta = \omega\sqrt{\mu\epsilon} = \frac{2\pi}{\lambda}$$

This solution represents an outgoing travelling wave on the antenna.

$$E_{\theta} = Z_0 H_{\phi} = \frac{Z_0}{r \sin \theta} H_0 e^{-j\beta r} \dots (13)$$

where  $Z_0$  is the intrinsic impedance of the medium. Equations (12) and (13) give the variation of the magnetic and electric fields of a TEM outgoing wave in the space between the cones of a biconical antenna as a function of  $\theta$  and  $r$ . The fields are independent of  $\phi$ .

The voltage  $V(r)$  between points 1 and 2 on the cones at a distance  $r$  from the terminals can now be obtained by taking the line integral of  $E_{\theta}$  along a great circle between the two points. Thus

$$V(r) = \int_{\theta_{nc}}^{\pi - \theta_{nc}} E_{\theta} r d\theta \dots (14)$$

$$= Z_0 H_0 e^{-j\beta r} \int_{\theta_{nc}}^{\pi - \theta_{nc}} \frac{d\theta}{\sin \theta} = Z_0 H_0 e^{-j\beta r} \ln \frac{\cot(\theta_{nc}/2)}{\tan(\theta_{nc}/2)}$$

$$\text{or } V(r) = 2 Z_0 H_0 e^{-j\beta r} \ln(\cot \theta_{nc}/2) \dots (15)$$

The total current  $I(r)$  on the cone at a distance  $r$  from the terminals can be obtained by applying Ampere's law. Thus

$$I(r) = \int_0^{2\pi} H_{\phi} r \sin \theta d\phi = 2\pi r H_{\phi} \sin \theta \dots (17)$$

Now substituting  $H_{\phi}$  from (12) in (17) gives

$$I(r) = 2\pi H_0 e^{-j\beta r} \dots (18)$$

The characteristic impedance  $Z_k$  of the biconical antenna is

$$Z_k = \frac{V(r)}{I(r)} = \frac{Z_0}{\pi} \ln \cot \frac{\theta_{nc}}{2} = 120 \ln \cot \frac{\theta_{nc}}{2} \text{ (}\Omega\text{)} \dots (19)$$

$$Z_k = 120 \ln \cot \left( \frac{\theta_{nc}}{2} \right)$$

## Arrays of point sources

Case I. Two isotropic point sources of same amplitude and phase

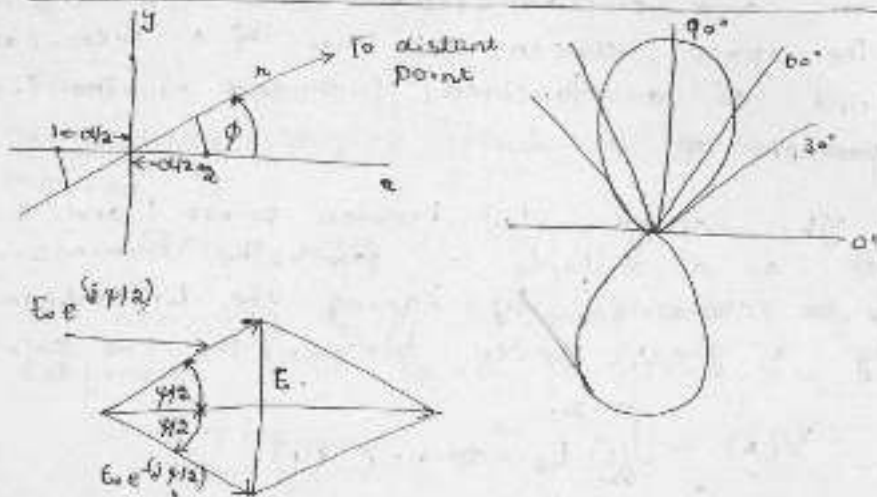

At a distant point in the direction  $\phi$  the field from source 1 is retarded by  $\frac{1}{2} d \cos \phi$ , while the field from source 2 is advanced by  $\frac{1}{2} d \cos \phi$ , where  $d$  is the distance between the sources expressed in radians; that is

$$d\psi = \left(\frac{2\pi}{\lambda}\right) d \cos \phi \quad (\text{Path difference})$$

The total field at a large distance  $r$  in the direction  $\phi$  is then

$$E = E_0 e^{-j\psi/2} + E_0 e^{j\psi/2} \quad \dots (1)$$

where  $\psi = d \cos \phi$  and the amplitude of the field components at the distance  $r$  is given by  $E_0$ .

Equation (1) may be written as

$$E = \frac{2E_0}{2} \frac{e^{j\psi/2} + e^{-j\psi/2}}{2} \quad \dots (2)$$

$$= 2E_0 \cos \frac{\psi}{2} = 2E_0 \cos \left(\frac{d \cos \phi}{\lambda}\right) \quad \dots (3)$$

We note that the phase of the total field does not change as a function of  $\psi$ .

If  $2E_0 = 1$ ,  $d = \frac{\lambda}{2}$  then  $d\psi = \pi$

and (3) becomes

$$E = \cos \left(\frac{\pi}{2} \cos \phi\right) \quad \dots (4)$$

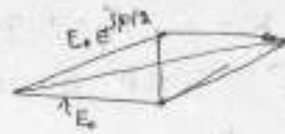
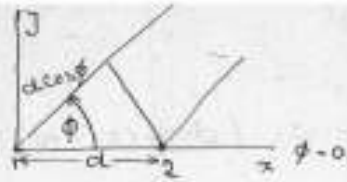

The field from source 1 is taken as reference, the field from source 2 in the direction  $\phi$  is advanced by  $d \cos \phi$ . Thus, the total field  $E$  at a distance  $r$  is the vector sum of the two fields from the two sources as given by

$$E = E_0 + E_0 e^{j\gamma} \quad \dots (5)$$

where  $\gamma = d \cos \phi$

$$\therefore E = 2E_0 \cos \frac{\gamma}{2} = 2E_0 \cos \left( \frac{d \cos \phi}{\lambda} \right) \quad \dots (6)$$

The phase of the total field  $E$  is not constant in this case but  $\frac{\gamma}{2}$

$$\text{as } E = E_0 (1 + e^{j\gamma}) = 2E_0 e^{j\gamma/2} \cos \frac{\gamma}{2} \quad \dots (7)$$

Case II Two isotropic point sources of same Amplitude but opposite phase

The total field at a large distance  $r$  in the direction of  $\phi$  is given as

$$E = E_0 e^{j\gamma/2} - E_0 e^{-j\gamma/2} \quad \dots (8)$$

$$= 2jE_0 \sin \frac{\gamma}{2} = 2jE_0 \sin \left( \frac{d \cos \phi}{\lambda} \right) \quad \dots (9)$$

if  $2jE_0 > 1$  and  $\frac{d}{\lambda} = \frac{\lambda}{2}$ ,  
then  $E = \sin \left( \frac{\pi}{2} \cos \phi \right) \quad \dots (10)$

The directions  $\phi_m$  of maximum field are obtained by setting the argument of (10) equal to  $\pm (2k+1)\frac{\pi}{2}$ . Thus,

$$\frac{\pi}{2} \cos \phi_m = \pm (2k+1)\frac{\pi}{2} \quad \dots (11a)$$

where  $k = 0, 1, 2, 3, \dots$  for  $k=0$ ,  $\cos \phi_m = \pm 1$  and  $\phi_m = 0^\circ$  and  $180^\circ$

The null directions  $\phi$  are given as

$$\frac{1}{2} \cos \phi_0 = \pm k r \quad (11b)$$

For  $k=0$ ,  $\phi_0 = \pm 90^\circ$

The half-power points (directions) are given by

$$\frac{\pi}{2} \cos \phi = \pm (2kr) \frac{\pi}{4} \quad (11c)$$

For  $k=0$ ,  $\phi = \pm 60^\circ, \pm 120^\circ$

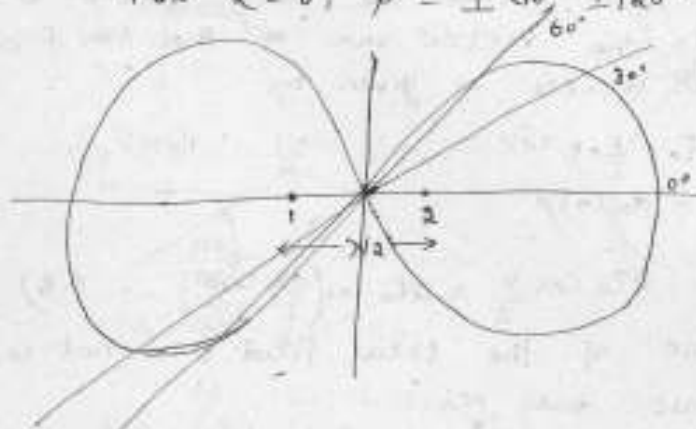

(Relative field pattern for 2 isotropic point sources of the same amplitude and opposite phase, spaced  $\frac{\lambda}{2}$  apart)

Case III. Two isotropic point sources of the same amplitude but in phase quadrature

Let the two point sources be located as in Fig. 1. Taking the origin of the coordinates as the reference for phase, let source 1 be retarded by  $45^\circ$  and source 2 be advanced by  $45^\circ$ . Then the total field in the  $\phi$  direction at a large distance  $r$  is given by

$$E = E_0 \exp \left[ +j \left( \frac{dr \cos \phi}{a} + \frac{\pi}{4} \right) \right] + E_0 \exp \left[ -j \left( \frac{dr \cos \phi}{a} + \frac{\pi}{4} \right) \right] \quad (18)$$

$$= 2E_0 \cos \left( \frac{\pi}{4} + \frac{dr}{a} \cos \phi \right) \quad (19)$$

If  $2E_0 = 1$  and  $d = \frac{\lambda}{2}$ ,

then

$$E = \cos \left( \frac{\pi}{4} + \frac{\pi}{2} \cos \phi \right) \quad (19)$$



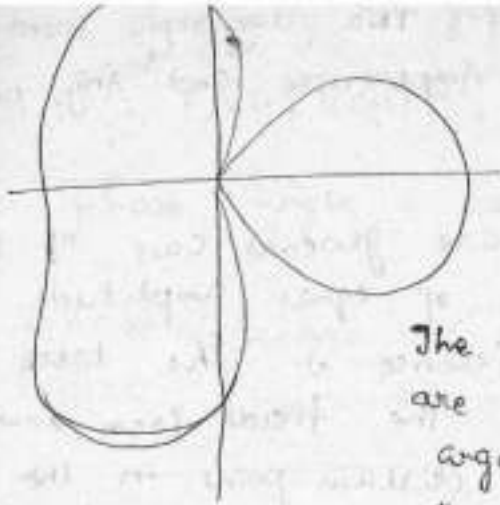

The directions  $\phi_m$  of maximum field are obtained by setting the argument of (14) equal to  $k\pi$ , where  $k = 0, 1, 2, 3, \dots$  so we obtain

$$\frac{\pi}{4} + \frac{\pi}{2} \cos \phi_m = k\pi \quad \dots (15)$$

for  $k = 0$ ,

$$\frac{\pi}{2} \cos \phi_m = -\frac{\pi}{4} \quad \dots (16)$$

$$\text{and } \phi_m = 120^\circ \text{ and } 240^\circ \quad \dots (17)$$

If  $d = \frac{\lambda}{4}$ , then

$$E = \cos\left(\frac{\pi}{4} + \frac{\pi}{4} \cos \phi\right) \quad \dots (18)$$

It is a cardioid-shaped, unidirectional pattern with maximum field in the negative  $x$  direction. The space pattern is a figure-of-revolution of this pattern around the  $x$  axis.

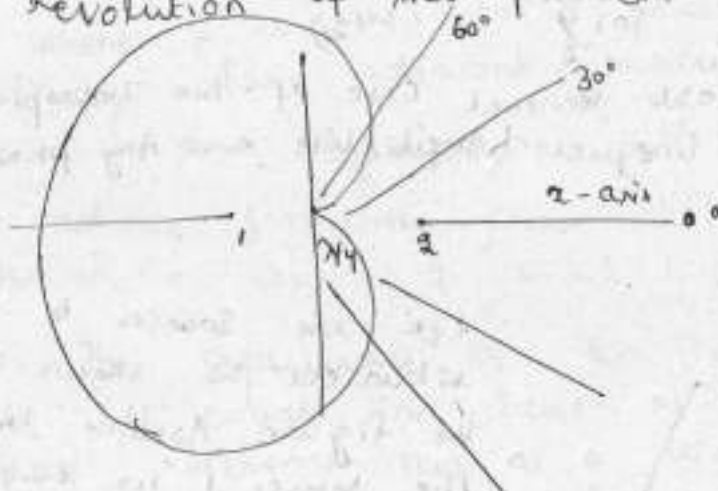

General case of Two Isotropic point sources of equal Amplitude and Any phase Difference

Let us consider a more general case of two isotropic point sources of equal amplitude but of any phase difference  $\delta$ . The total phase difference  $\psi$  between the fields from source 2 and source 1 at a distant point in the direction  $\theta$  is given as

$$\psi = d \cos \theta + \delta \quad (19)$$

If the phase reference is taken at the centerpoint of the array, the phase of the field from source 1 at a distant point is given by  $-\psi/2$  and that from source 2 by  $+\psi/2$ . The total field is then

$$E = E_0 (e^{i\psi/2} + e^{-i\psi/2}) = 2E_0 \cos \frac{\psi}{2} \quad \dots (20)$$

Normalizing (20), we have the general expression for the field pattern of two isotropic sources of equal amplitude and arbitrary phase

$$E = \cos \frac{\psi}{2} \quad \dots (21)$$

Case V. Most General Case of Two Isotropic point sources of Unequal Amplitude and Any phase Difference

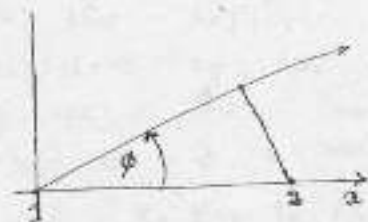

Let the sources be situated as shown in the figure. Assume that the source 1 has larger amplitude and that its field at a large distance  $r$  has an amplitude of  $E_0$ . Let the field from source 2 be of amplitude  $aE_0$  ( $0 < a < 1$ ) at the distance  $r$



Referring to the

phasor diagram, we get

$$E = E_0 \sqrt{(1 + a \cos \phi)^2 + a^2 \sin^2 \phi}$$

$$\text{phase angle} = \tan^{-1} \left( \frac{a \sin \phi}{1 + a \cos \phi} \right)$$

Linear Array of  $n$  Isotropic Point Sources of Equal Amplitude and Spacing

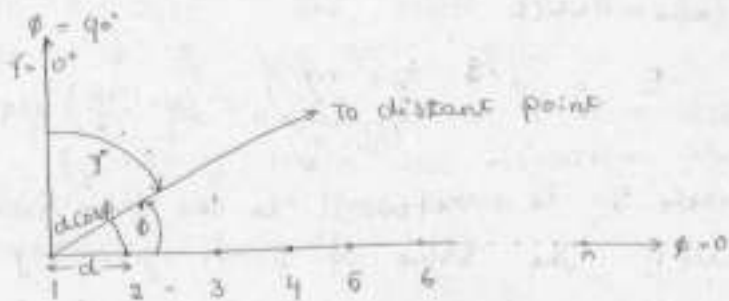

Arrangement of linear Array of  $n$  Isotropic point sources

The total field at a large distance in the direction  $\phi$  is given by

$$E = 1 + e^{j\psi} + e^{j2\psi} + e^{j3\psi} + \dots + e^{j(n-1)\psi} \dots (1)$$

where  $\psi$  is the total phase difference of the fields from adjacent sources as given by

$$\psi = \frac{2\pi}{\lambda} d \cos \phi + \delta = d \cos \phi + \delta \dots (2)$$

where  $\delta$  is the phase difference of adjacent sources, i.e. source 2 w.r.t 1, 3 w.r.t 2, etc.

The amplitudes of the fields from the sources are all equal and taken as unity, source 1 is the phase reference. Thus, at a distant point in the direction  $\phi$  the field from source 2 is advanced in phase w.r.t source 1 by  $\psi$ , the field from source 3 is advanced in phase w.r.t source 1 by  $2\psi$  etc.

Multiplying (1) by  $e^{j\psi}$ , we get,

$$E e^{j\psi} = e^{j\psi} + e^{j2\psi} + e^{j3\psi} + \dots + e^{jn\psi} \dots (3)$$

Now subtracting (3) from (1) and dividing by  $1 - e^{j\psi}$ , we get

$$E = \frac{1 - e^{jn\psi}}{1 - e^{j\psi}} \quad \dots (4)$$

$$= \frac{e^{jn\psi/2}}{e^{j\psi/2}} \left( \frac{e^{jn\psi/2} - e^{-jn\psi/2}}{e^{j\psi/2} - e^{-j\psi/2}} \right) \quad \dots (5)$$

from which

$$E = e^{j\phi} \frac{\left( \sin \frac{n\psi}{2} \right)}{\left( \sin \frac{\psi}{2} \right)} = \frac{\sin \left( \frac{n\psi}{2} \right)}{\sin \left( \frac{\psi}{2} \right)} \angle \phi \quad \dots (6)$$

where  $\phi$  is referred to the field from source 1. The value of  $\phi$  is given by

$$\phi = \frac{n-1}{2} \psi \quad \dots (7)$$

If the phase is referred to the centerpoint of the array, (6) becomes

$$E = \frac{\sin(n\psi/2)}{\sin(\psi/2)} \quad \dots (8)$$

In this case the phase pattern is a step function as given by the sign of (8). The phase of the field is constant wherever  $E$  has a value but changes sign when  $E$  goes through zero.

When  $\psi = 0$ , (6) or (8) is indeterminate so that for this case  $E$  must be obtained as the limit of (8) as  $\psi$  approaches zero. Thus, for  $\psi = 0$  we have the relation that

$$E = n \quad \dots (9)$$

This is the maximum value of that  $E$  can attain. Hence the value of the total field for  $E_{\max} = n$  is

$$E = \frac{1}{n} \frac{\sin(n\psi/2)}{\sin(\psi/2)} \quad \dots (10)$$

The field as given by (10) will be referred to as 'array factor':

### Case 1. Broadside Array (Sources in phase)

The first case is a linear array of  $n$  isotropic sources of the same amplitude and phase. Therefore,  $\delta = 0$  and  $\psi = d \sin \phi$  ... (10)

To make  $\psi = 0$  requires that  $\phi = (2k+1)\frac{\pi}{2}$  where  $k$  is 0, 1, 2, 3. The field is, therefore, a maximum when  $\phi = \frac{\pi}{2}$  and  $\frac{3\pi}{2}$  ... (11a)

That is, the maximum field is in a direction normal to the array. Hence, this condition, which is characterized by in-phase sources ( $\delta = 0$ ) results in a "broadside" type of array.

### Case 2. Ordinary End-fire Array

Let us now find the phase angle between adjacent sources that is required to make the field a maximum in the direction of the array ( $\phi = 0$ ).

An array of this type may be called an "end-fire" array. For this we substitute the conditions  $\psi = 0$  and  $\phi = 0$  into (2), from which

$$\delta = -d \sin \phi \quad \dots (12)$$

Hence, for an end-fire array, the phase between sources is retarded progressively by the same amount as the spacing between sources in radians.

### Case 3. End-fire Array with Increased Directivity

The situation in Case 2, namely, for  $\delta = -d \sin \phi$ , produces a maximum field in the direction  $\phi = 0$  but does not give the maximum directivity. A larger directivity is obtained by increasing the phase change between sources so that

$$\delta = -\left(d \sin \phi + \frac{\pi}{n}\right) \quad \dots (13)$$

This condition will be referred to as the condition for "increased directivity". Thus for the phase difference

of the fields at a large distance we have

$$\psi = d_n(\cos\phi - 1) - \frac{\pi}{n} \dots (14)$$

To realize the directivity increase afforded by the additional phase difference requires that  $|\psi|$  be restricted in its range to a value of  $\frac{\pi}{n}$  at  $\phi = 0$  and a value in the vicinity of  $\pi$  at  $\phi = 180^\circ$ . This can be fulfilled if the spacing is reduced for example

The maximum of the field pattern occurs at  $\phi = 0$  and  $\psi = -\frac{\pi}{n}$ . In general, any increased directivity end-fire array, with maximum at  $\psi = -\frac{\pi}{n}$ , has a normalized field pattern given by

$$E = \sin\left(\frac{\pi}{2n}\right) \frac{\sin(n\psi/2)}{\sin(\psi/2)} \dots (15)$$

Case 4. Array with Maximum Field in an Arbitrary Direction Scanning Array

Let us consider the case of an array with a field pattern having a maximum in some arbitrary direction  $\phi$ , not equal to  $\frac{k\pi}{n}$ , where  $k = 1, 2, 3$ . Then (2) becomes

$$0 = d_n(\cos\phi + \delta) \dots (16)$$

By specifying the spacing  $d_n$ , the required phase difference  $\delta$  is then determined by (16) conversely, by changing  $\delta$  the beam direction  $\phi$  can be shifted or scanned.

## Null Directions For Arrays of $n$ Isotropic Point Sources of Equal Amplitude and Spacing

The null directions for an array of  $n$  isotropic point sources of equal amplitude and spacing occur when  $E=0$  or provided that the denominator of (1) is not zero, when

$$e^{jn\psi} = 1 \quad \dots (1)$$

Equation (1) requires that

$$n\psi = \pm 2k\pi \quad \dots (2)$$

where  $k=1, 2, 3, \dots$

Substituting the value of  $\psi$  in (2) to (3), we get

$$\psi = d_n \cos \phi_0 + \delta = \pm \frac{2k\pi}{n} \quad \dots (3)$$

$$\therefore \phi_0 = \cos^{-1} \left[ \left( \pm \frac{2k\pi}{n} - \delta \right) \frac{1}{d_n} \right] \quad \dots (4)$$

where  $\phi_0$  gives the direction of the pattern null. We note that values of  $k$  must be excluded for which  $k=mn$ , where  $m=1, 2, 3, \dots$ . Thus, if  $k=mn$ , (2) reduces to  $\psi = \pm 2m\pi$  and the denominator of (4) equals zero so that the null direction of (1), that the numerator of  $\frac{1 - e^{jn\psi}}{1 - e^{j\psi}}$  be zero is insufficient.

In a broadside array  $\delta=0$ , so that (4)

becomes

$$\phi_0 = \cos^{-1} \left( \pm \frac{2k\pi}{nd_n} \right) = \cos^{-1} \left( \pm \frac{k\lambda}{nd} \right) \quad \dots (5)$$

If  $\phi_0$  in (5) is replaced by its complementary angle  $\phi_0'$ , then (5) becomes

$$\phi_0' = \sin^{-1} \left( \pm \frac{k\lambda}{nd} \right) \quad \dots (6)$$

If the array is long, so that  $nd \gg k\lambda$ ,

$$\phi_0' = \frac{k\lambda}{nd} \quad \dots (7)$$

The first nulls either side of the maximum occur for  $k=1$ . These angles will be designated  $\phi_0$ . Thus,

$$\phi_0 \approx \pm \frac{\lambda}{nd} \quad (8)$$

and the total beam width of the main lobe between first nulls for a long broadside array is then

$$2\phi_0 \approx \frac{2\lambda}{nd} \quad (9)$$

For ordinary end-fire arrays,  $\delta = -\frac{\pi}{2}$ . Thus,

(3) becomes

$$\cos \phi_0 - 1 = \pm \frac{2k\pi}{nd} \quad (10)$$

from which we obtain

$$\frac{\phi_0}{2} = \sin^{-1} \left( \pm \sqrt{\frac{k\pi}{nd}} \right) \quad (11)$$

$$\text{or } \phi_0 = 2 \sin^{-1} \left( \pm \sqrt{\frac{k\pi}{nd}} \right) \quad (12)$$

If the array is long, so that  $nd \gg k\pi$ ,

(12) becomes

$$\phi_0 \approx \pm \sqrt{\frac{2k\pi}{nd}} \quad (13)$$

The first nulls either side of the main lobe occur for  $k=1$ . These angles will be designated  $\phi_0$ . Thus,

$$\phi_0 \approx \pm \sqrt{\frac{2\lambda}{nd}} \quad (14)$$

and the total beam width of the main lobe between first nulls for a long ordinary end-fire array is then

$$2\phi_0 \approx 2 \sqrt{\frac{2\lambda}{nd}} \quad (15)$$

For end-fire arrays with increased directivity, the condition is that

$$\delta = - \left( \frac{\pi}{n} \right). \text{ Thus for this case}$$



(3) becomes

$$d_n (\cos \phi_0 - 1) - \frac{\pi}{n} = \pm 2 \frac{k\pi}{n} \dots (16)$$

from which

$$\frac{\phi_0}{2} = \sin^{-1} \left[ \pm \sqrt{\frac{\pi}{2and_n} (2k-1)} \right] \dots (17)$$

$$\text{or } \phi_0 = 2 \sin^{-1} \left[ \pm \sqrt{\frac{\lambda}{4nd} (2k-1)} \right] \dots (18)$$

If the array is long, so that  $nd \gg k\lambda$ , (18) becomes

$$\phi_0 \approx \pm \sqrt{\frac{\lambda}{nd} (2k-1)} \dots (19)$$

The first null either side of the main lobe,  $\phi_{01}$ , occurs for  $k=1$ . Thus,

$$\phi_{01} \approx \pm \sqrt{\frac{\lambda}{nd}} \dots (20)$$

and the total beam width of the main lobe between first nulls for a long end-fire array with increased directivity is then

$$2\phi_{01} \approx 2\sqrt{\frac{\lambda}{nd}} \dots (21)$$

This width is  $\left(\frac{1}{\sqrt{2}}\right)$  or 71% of the width of the ordinary end-fire array.

The helix is a basic 3-dimensional geometric form. A helical wire on a uniform cylinder becomes a straight wire when unwound by rolling the cylinder on a flat surface. Viewed end-on, a helix projects as a circle. Thus a helix combines the geometric forms of a straight line, a circle and a cylinder. In addition, a helix has handedness; it can be either left- or right handed.

The following symbols will be used to describe a helix.

$D$  = diameter of helix (center to center)

$C$  = circumference of helix =  $\pi D$

$S$  = spacing between turns (center to center)

$d$  = pitch angle =  $\tan^{-1} \frac{S}{\pi D}$

$L$  = length of 1 turn

$n$  = number of turns

$A$  = axial length =  $nS$

$d$  = diameter of helix conductor

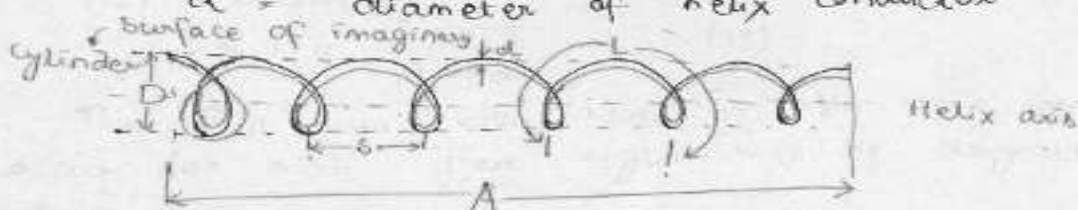

(Helix and associated dimensions)

The equation of a helix is

$$x = a \cos t$$

$$y = a \sin t$$

$$z = bt$$

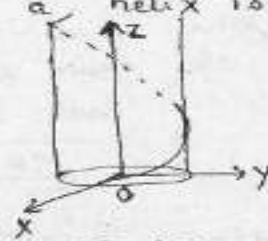

A subscript  $\lambda$  signifies that the dimension is measured in free-space wavelengths. For example,  $D_\lambda$  is the helix

diameter in free-space wavelength.

If 1 turn of a circular helix is unrolled on a flat plane, the relation between the spacing  $b$ , circumference  $c$ , turn length  $L$  and pitch angle  $\alpha$  are as illustrated by the following triangle.



When  $b = c$ ,  $\alpha = 0$  and the helix becomes a loop, on the other hand, when the diameter is zero,  $\alpha = 90^\circ$  the helix becomes a linear conductor.

The term transmission mode is used to describe the manner in which an electromagnetic wave is propagated along an infinite helix as though the helix constitutes an infinite transmission line or waveguide. A variety of different transmission modes are possible.

The term radiation mode is used to describe the general form of the far-field pattern of a finite helical antenna. Although many patterns are possible, two kinds of are of particular interest one is the axial (or beam) mode of radiation ( $R_0$  mode, beam on the axis) and the other is the normal mode of radiation ( $R_n$  mode, radiation maximum perpendicular to axis).

The lowest transmission mode for a helix has adjacent regions of positive and negative charge separated by many turns. This mode is designated as the  $T_0$  transmission mode and the instantaneous charge distribution is shown in the following figure.

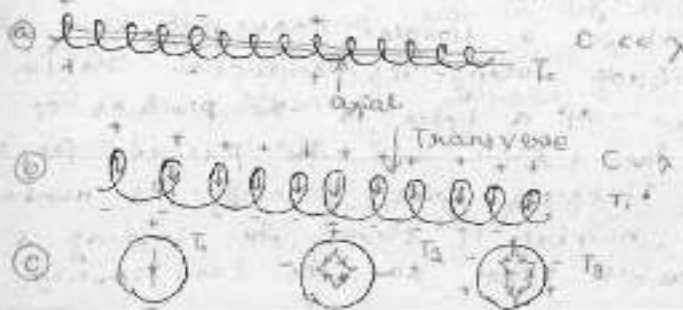

The  $T_0$  mode is important when the length of 1 turn is small compared to the wavelength ( $L \ll \lambda$ ) and is the mode occurring on low-frequency inductances. It is also the important transmission mode in the travelling wave tube since the adjacent regions of positive and negative charge are separated by an appreciable axial distance, a substantial axial component of the electric field is present, and in the travelling wave tube this field interacts with the electron stream. If the condition  $L \ll \lambda$  is arbitrarily selected as a boundary for the  $T_0$  transmission mode, the region of the helix dimensions for which this mode is important is within the  $T_{0R}$  area.

A helix excited in the  $T_0$  transmission mode may radiate. Let us consider the case when the helix is very short ( $nL \ll \lambda$ ) and the current is assumed to be of uniform magnitude and in phase along the entire helix. It is theoretically possible to approximate this condition on a small end-loaded helix. However, its radiation resistance is small. The maximum field from the helix is normal to the helix axis for all helix dimensions provided only that  $nL \ll \lambda$ . Thus, this condition is called a "normal radiation mode" ( $R_0$ ). Any component of the field has a sine variation with  $\theta$ .

#### Axial-mode patterns and the phase velocity of wave propagation on monofilar helices

As a first approximation, a monofilar helical antenna radiating in the axial mode may be assumed to have a single traveling wave of uniform amplitude along its conductor. The far field pattern of a helix is the product of the pattern for 1 turn and the pattern for an array of  $n$  isotropic point sources. The number  $n$  equals the number of turns. The spacing  $s$  between sources is equal to the turn spacing.

when the helix is long, (No. 71), its array pattern is much sharper than the single-turn pattern and hence largely determines the shape of the total far-field pattern. Hence, the approximate far-field pattern of a long helix is given by the array pattern.

The array pattern or array factor  $E$  for an array of  $n$  isotropic point sources arranged as in the following figure is given as

$$E = \frac{\sin(n\psi/2)}{\sin(\psi/2)}$$

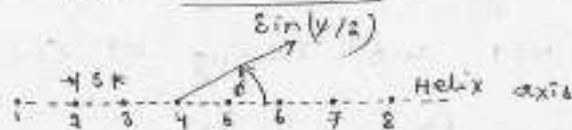

where  $n$  = number of sources and

$$\psi = S_2 \cos \phi + \delta \quad \dots (2)$$

$$\text{where } S_2 = \left(\frac{2\pi}{\lambda}\right) s$$

for the present case, (2) becomes

$$\psi = 2\pi \left( S_2 \cos \phi - \frac{L_2}{\beta} \right) \quad \dots (3)$$

where  $\beta = \frac{v}{c}$  = relative phase velocity of wave propagation along the helical conductor,  $v$  being the phase velocity along the helical conductor and  $c$  being the velocity of light in free space.

If the fields from all sources are in phase at a point on the helix axis ( $\phi = 0$ ), the radiation will be in the axial mode. For the fields to be in phase (end-fire condition) requires that

$$\psi = -2\pi m \quad \dots (4)$$

where  $m = 0, 1, 2, 3, \dots$

The minus sign in (4) results from the fact that the phase of source 2 is retarded by  $\frac{2\pi L_2}{\beta}$  w.r.t. source 1. Source 3 is similarly retarded w.r.t. source 2, etc.

∴ NB: putting  $\phi = 0$  and equating (3) and (4), we have

$$\frac{L_2}{\beta} = S_2 + m \quad \dots (5)$$

when  $m=1$  and  $p=1$ , we have the relation

$$L_\lambda - S_\lambda = \lambda \quad \text{or} \quad L - S = \lambda \quad (6)$$

This is an approximate relation between the turn length and spacing required for a helix radiating in the axial mode.

Since for a helix  $L^2 = (\pi D)^2 + S^2$ , (6) can be rewritten as

$$D_\lambda = \frac{\sqrt{2S_\lambda + 1}}{\pi} \quad \text{or} \quad L_\lambda = \sqrt{2S_\lambda + 1} \quad (7)$$

when  $m=1$  and solving (5) for  $p$ , we have

$$p = \frac{L_\lambda}{S_\lambda + 1} \quad (8)$$

(8) can also be expressed as

$$p = \frac{1}{\sin \alpha + (\cos \alpha / c_\lambda)} \quad (9)$$

Equation (9) gives the required variation in the relative phase velocity  $p$  as a function of the circumference  $L_\lambda$  for in-phase fields in the axial direction.

If the increased directivity condition is presumed to exist, (4) becomes

$$\gamma = - \left( \alpha m + \frac{\pi}{2} \right) \quad (10)$$

Now equating (10) and (3), putting  $\beta = 0$  and solving for  $p$  we have

$$p = \frac{L_\lambda}{S_\lambda + m + \frac{1}{2} \alpha n} \quad (11)$$

For the case of interest  $m=1$  and

$$p = \frac{L_\lambda}{S_\lambda + \frac{1}{2} \alpha n} \quad (12)$$

For large values of  $n$ , (12) reduces to (8). Equation (12) can also be

expressed as

$$\rho = \frac{1}{\sin \alpha + \frac{(2n+1)}{2n} (\cos \alpha / c_n)} \dots (13)$$

The increased directivity condition is approximated as a natural condition on helices radiating in the axial mode.

Monofilar Axial- Mode Single turn Patterns

Let us proceed to develop the far-field pattern from a single turn of a monofilar helix radiating in the axial mode. It is assumed that the single turn has a uniform traveling wave along its entire length. The product of the single-turn pattern and the array factor then gives the total helix pattern.

A circular helix may be treated approximately by assuming that it is of square cross section. The total field from a single turn is then the resultant of the fields of four short, linear antennas.

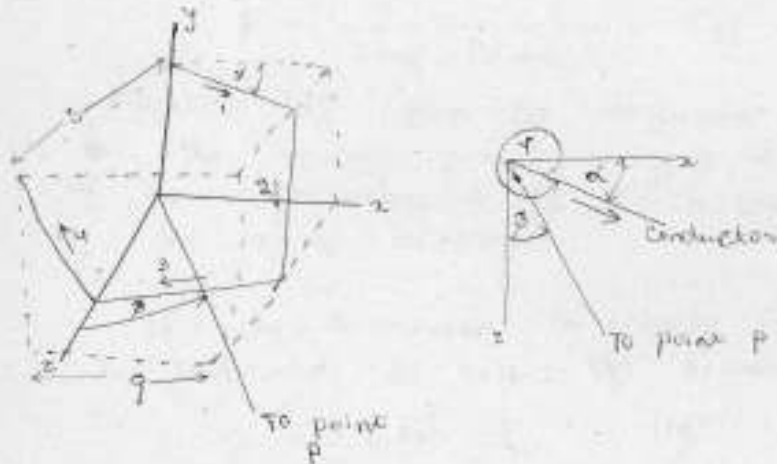

A helix of square cross section, can of course be treated exactly by this method. Measurements indicate that the difference between helices of circular and square cross section is so small.

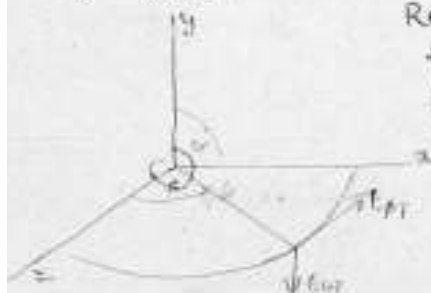

Referring to the figure below, the far electric field components  $E_{\theta}$  and  $E_{\phi}$  in the  $xz$  plane as a function of  $\rho$  for a single-turn helix.



Let the area of the square helix be equal to that of the circular helix so that-

$$g = \frac{\sqrt{\pi} D}{2} \quad \boxed{\frac{\pi D^2}{4} = g^2}$$

where  $g$  is as shown.

The far magnetic field for a linear element with a uniform traveling wave is given by

$$|H_y| = \frac{I_0 b}{2\pi r_1} \left\{ \frac{\sin \phi}{1 - \rho \cos \phi} \sin \left[ \frac{\omega b}{2pc} (1 - \rho \cos \phi) \right] \right\} e^{-i\omega t}$$

$$\text{phase angle} = k a r_1 \left[ \omega \left( t - \frac{r_1}{c} \right) - \frac{\omega b}{2pc} (1 - \rho \cos \phi) \right]$$

Let us multiply  $H_y$  by  $z$  of free space and put  $\phi = \frac{3\pi}{4} + \alpha + \beta$ ,  $t = 0$ , and  $b = \frac{g}{\cos \alpha}$ , we

obtain the expression for the  $\phi$  component of  $E_{\phi 1}$  of the far field in the  $xz$  plane due to element of the square helix as follows:

$$E_{\phi 1} = k \frac{\sin \gamma}{A} \sin \beta A \left( \beta - \frac{\omega r_1}{c} - \beta A \right) \dots (2)$$

$$\text{where } k = \frac{I_0 p z}{2\pi r_1}$$

$$A = 1 - \rho \cos \phi$$

$$\beta = \frac{\omega g}{2pc \cos \alpha}$$

The expressions for  $E_{\phi 2}$ ,  $E_{\phi 3}$  etc. due to elements 2, 3 and 4 of the square turn are obtained in a similar way. Since the elements are all dissimilar sources, the total  $\phi$  component,  $E_{\phi T}$ , from a single square turn is obtained by adding the fields from the four elements at each angle  $\phi$  for which the total field is calculated. The sum of the fields from the four elements is then

$$E_{\phi T} = k \frac{\sin \phi}{A} \sin \beta A \left( -\beta A - \frac{\omega r_1}{c} \right)$$

$$+ k \frac{\sin \beta A^* \sin \alpha \sin \phi}{A^*} \left[ -\beta A^* - \frac{\omega r_1}{c} + \frac{\omega}{c} \left( \frac{b \cos \phi}{4} + g \sin \phi - r_1 \right) \right]$$

$$+ k \frac{\sin \phi}{A'} \sin \beta A' \left[ -\beta A' - \frac{\omega r_1}{c} + \frac{\omega}{c} \left( \frac{b \cos \phi}{4} + g \sin \phi - r_1 \right) \right]$$

$$+ k \frac{\sin \beta A'' \sin \alpha \sin \phi}{A''} \left[ (-\beta A'' - \frac{2L\omega}{4pc} + \frac{\omega}{c} (\frac{2\beta \cos \phi - \alpha}{4})) \right] \quad \dots (3)$$

where  $\gamma = \frac{2\pi}{\lambda} + \alpha + \phi$   $\gamma'' = \frac{\pi}{\lambda} - \alpha + \phi$

$$\gamma'' = \cos^{-1}(\sin \alpha \cos \phi)$$

$$A = 1 - p \cos \gamma, \quad A' = 1 - p \cos \gamma', \quad A'' = 1 - p \cos \gamma''$$

When a helix of circular cross section is being calculated  $L = \pi D / \cos \alpha$  in (3), while for a helix of square cross section  $L = 4b$ .

If the contribution of elements 2 and 4 are neglected, which is a good approximation when both  $\alpha$  and  $\phi$  are small, the expression for  $E_{\phi T}$  is considerably simplified. Making this approximation, letting  $k=1$  and  $\alpha_0 = \text{constant}$ , we obtain

$$E_{\phi T} = \frac{\sin \gamma'}{A'} \sin \beta A' (L - \beta A) + \frac{\sin \gamma''}{A''} \sin \beta A'' \left[ (-\beta A'' - 2\sqrt{\beta} B + \pi) (\sin \phi \cos \phi + \sqrt{\beta} D \pi \sin \alpha) \right] \quad \dots (4)$$

Equation (4) applies specifically to helices of circular cross sections, so that  $B$  in (4) is

$$B = \frac{D \lambda \pi \alpha / 2}{2p \cos \alpha} \quad (5)$$

Equation (4) gives the approximate pattern of the  $\phi$  component of the far field in the  $xz$  plane from a single-turn helix of circular cross section.

In the case of the  $\theta$  component of the far field in the  $xz$  plane only elements 2 and 4 contribute. putting  $k=1$  the magnitude of the approximate  $\theta$  pattern of the far field of a single-turn helix of circular cross section is

$$|E_{\theta}| = 2 \frac{I_0 r \sin^2 \theta \cos \alpha}{A^2 (1 - \sin^2 \theta \cos^2 \phi)^{3/2}}$$

$$\sin \frac{1}{2} [\pi (S_1 \cos \phi - \sqrt{\pi} D \sin \phi) - 2\sqrt{\pi} B] \dots (6)$$

Let us proceed to find the field radiated by a traveling wave on a thin linear conductor. Let us consider a conductor of length  $b$  coincident with the  $z$  axis and with one end at the origin of a cylindrical coordinate system  $(r, \phi, z)$  as in the following figure. It is assumed that a single, uniform traveling wave is moving to the right along the conductor.

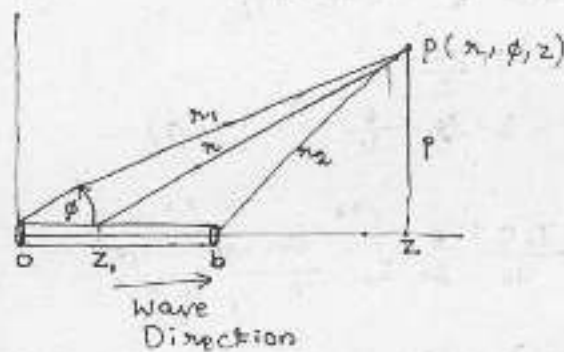

Since the current is entirely in the  $z$  direction, the magnetic field has but one component  $H_{\phi}$ . The  $\phi$  direction is normal to the page at  $P$  and its positive sense is outward from the page. The magnetic field  $H_{\phi}$  can be obtained from the Hertz Vector  $\Pi$ . Since the current is entirely in the  $z$  direction, the Hertz Vector has only a  $z$  component. Thus

$$H_{\phi} = j\omega \epsilon (\nabla \times \Pi)_{\phi} = -j\omega \epsilon \frac{\partial \Pi_z}{\partial r} \dots (1)$$

where  $\Pi_z$  is the  $z$  component of the retarded Hertz vector at the point  $P$ , as given by

$$\Pi_z = \frac{1}{4\pi j\omega \epsilon} \int_0^b \frac{[I]}{r} dz_1 \dots (2)$$

$$\text{where } [I] = I_0 \sin\left(t - \frac{z}{c} - \frac{z_1}{v}\right) \dots (3)$$

where  $z_1$  = a point on the conductor  
and  $v = pc$  or  $\beta = \frac{v}{c}$  ... (4)

In (4),  $\beta$  is the ratio of the velocity along the conductor  $v$  to the velocity of light  $c$ . This ratio will be called the relative phase velocity.

Let  $u = \frac{z - z_1}{c - \beta v}$  and (5)

as  $\lambda = \sqrt{(z - z_1)^2 + a^2}$  (6)

we have  $\frac{du}{dz_1} = \frac{z - z_1}{c - \beta v} - \frac{1}{c - \beta v}$  (7)

$$\therefore \frac{\Pi}{z} = \frac{I_0 c}{4\pi j \omega \epsilon} \int_{u_1}^{u_2} \frac{\sin \omega u}{z - z_1 - (c - \beta v) u} du \quad (8)$$

where  $u_1 = t - \frac{z_1}{c}$   
and  $u_2 = t - \frac{z_2}{c}$

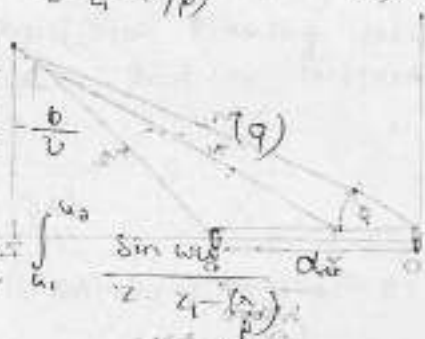

$$H_z = \frac{I_0 c}{4\pi} \frac{\partial}{\partial z} \int_{u_1}^{u_2} \frac{\sin \omega u}{z - z_1 - (c - \beta v) u} du$$

Very large ( $z \gg b$ )

$$\therefore H_z = -\frac{I_0 c}{4\pi} \frac{\partial}{\partial z} \left( \frac{-\cos \omega u_2 + \cos \omega u_1}{z - \frac{\lambda}{p}} \right) \quad (11)$$

$$= \frac{I_0 c \omega}{4\pi p} \frac{(z - \frac{\lambda}{p})(\sin \omega u_2 - \sin \omega u_1) + \frac{\lambda}{21p} (\cos \omega u_2 - \cos \omega u_1)}{(z - \frac{\lambda}{p})^2} \quad (12)$$

At arbitrarily large distances, i.e.

where  $\sqrt{z^2 - \frac{\lambda^2}{p^2}} \gg \frac{\lambda}{21p}$

and for the case where

(12) reduces to  $\dots$

$$H\phi = \frac{I_0}{4\pi^2} \frac{\sin\phi\theta}{\cos\theta - 1/p} (\sin wu_2 - \sin wu_1) \dots (13)$$

Where the relations have been introduced for  $x > b$  so that

$$\frac{z}{x} = \cos\theta \quad \text{and} \quad \frac{p}{x} = \sin\theta \dots (14)$$

$$H\phi = \frac{I_0 p}{2\pi^2 x} \left\{ \frac{\sin\phi}{1 - p\cos\theta} \sin \left[ \frac{\omega b}{2pc} (1 - p\cos\theta) \right] \right\} \\ \left( \left[ \omega \left( t - \frac{r_1}{c} \right) - \frac{\omega b}{2pc} (1 - p\cos\theta) \right] \dots (15) \right)$$

## Monofilar and Multifilar Normal-Mode Helical Antennas

Normal is being used in the sense of perpendicular to or at right angles to the helix axis.

When the helix circumference is approximately a wavelength the axial mode of radiation is dominant but when the circumference is much smaller the normal mode is dominant.

Let us consider a helix oriented with axis coincident with  $z$  axis.

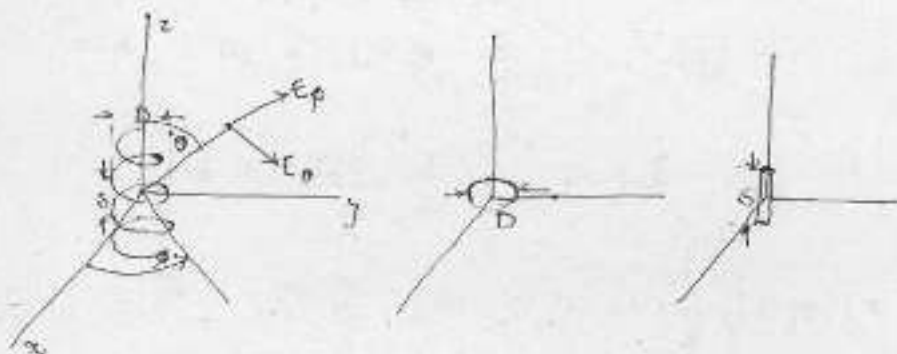

If the dimensions are small ( $nl \ll \lambda$ ), the maximum radiation is in the  $xy$  plane for a helix oriented as in the figure above with zero field in the  $z$  direction when the pitch angle is zero. The helix becomes a loop when the pitch angle is  $90^\circ$ . The helix straightens out into a linear antenna.

The far field of a helix may be described by two components of the electric field,  $E_\theta$  and  $E_\phi$ .

Let us now develop expressions for the far field patterns of these components for a small short helix. The development is facilitated by assuming that the helix consists of a number of small loops and short dipoles connected in series.



The current is assumed to be uniform in magnitude and phase over the entire length of the helix. Since the helix is small, the far-field pattern is independent of the number of turns. Hence it suffices to calculate the far-field patterns of a single small loop and one short dipole.

The far field of a small loop has only an  $E_\theta$  component. Its value is given as

$$E_\theta = \frac{120 \pi^2 (I) \sin \theta}{\lambda^2} \frac{A}{r} \quad \dots (1)$$

where  $A = \text{area of the loop} = \frac{\pi D^2}{4}$

The far field of the short dipole has only an  $E_\theta$  component. Its value is given as

$$E_\theta = j \frac{60 \pi^2 (I) \sin \theta}{\lambda} \frac{b}{r} \quad \dots (2)$$

Equations (1) and (2) indicate that  $E_\theta$  and  $E_\theta$  are in phase quadrature. To obtain the axial ratio, we write

$$AR = \frac{|E_\theta|}{|E_\theta|} = \frac{8\lambda}{2\pi A} = \frac{257}{\pi D^2} = \frac{257}{C_\lambda^2}$$

A monofilar normal-mode helix fulfilling the condition, i.e.  $|E_\theta| = |E_\theta|$  giving  $AR = 1$  and resulting in circular polarization (zero field in the  $z$  direction) is a resonant, narrow-band antenna.

## CONTINUOUS ARRAYS

Let us consider continuous arrays of point sources, i.e. arrays of an infinite number of sources separated by infinitesimal distances. By Huygen's principle, a continuous array of point sources is equivalent to a continuous field distribution.

We shall now develop an expression for the far field of a continuous array of point sources of equal amplitude and of the same phase. Let the array of length  $a$  be parallel to the  $y$  axis with its center at the origin as indicated in the figure.

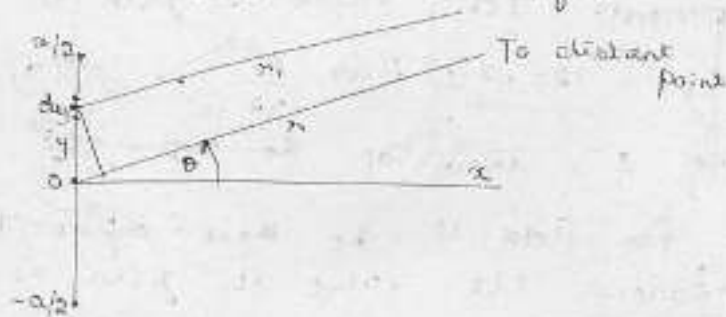

The field  $dE$  at a distant point in the direction  $\theta$  due to the point sources in the infinitesimal length  $dy$  at a distance  $y$  from the origin is

$$dE = \frac{A}{r_1} e^{j\beta y} \left[ e^{-j\beta r_1} \right] dy = \frac{A}{r_1} e^{j(\omega t - \beta r_1)} dy$$

where  $\beta = \frac{\omega}{c} = \frac{2\pi}{\lambda}$  and  $A$  is a constant involving amplitude. The total field at the distant point is then

$$E = \int_{-a/2}^{a/2} \frac{A}{r_1} e^{j(\omega t - \beta r_1)} dy$$
$$= \frac{A e^{j\omega t}}{r_1} \int_{-a/2}^{a/2} e^{-j\beta y} dy$$

$$\text{But } r_1 = r - y \sin \theta$$



$$E = A' \int_{-a/2}^{a/2} e^{j\beta y \sin \theta} dy$$

$$\text{where } A' = \frac{A e^{j(\omega t - \beta x)}}{r}$$

Thus,

$$E = \frac{2A'}{\beta \sin \theta} \frac{e^{j(\beta a/2) \sin \theta} - e^{-j(\beta a/2) \sin \theta}}{2j}$$

$$= \frac{2A'}{\beta \sin \theta} \sin \left( \frac{\beta a \sin \theta}{2} \right)$$

$$\text{Let } \psi' = \beta a \sin \theta = a \sin \theta$$

where  $a = \beta a = \frac{2\pi}{\lambda} a = \text{array length} \cdot \text{rad}$

Then

$$E = \frac{2A'}{\beta \sin \theta} \sin \frac{\psi'}{2}$$

$$\text{But } \beta \sin \theta = \frac{\psi'}{a}$$

$$E = a A' \frac{\sin(\psi'/2)}{\psi'/2}$$

Normalizing  $E$  gives

$$E = \frac{\sin(\psi'/2)}{\psi'/2}$$

This equation expressed the far field as Fraunhofer diffraction pattern of a continuous broadside array of length  $a$  having uniform amplitude and phase. For  $n$  discrete equally spaced sources, it was previously shown that the normalized value of the total field is

$$E = \frac{\sin(n\psi/2)}{n \sin(\psi/2)}$$

where  $\psi = d \cos \theta + \delta$

For in-phase sources,  $\delta = 0$ .

$$\text{Thus } \psi = \theta + \frac{\pi}{2}$$

$$\psi = -d \sin \theta = -\beta d \sin \theta$$

For small values of  $\psi$ , which occur for small values of  $\theta$ ,  $d$  or both,  $E$  can be

expressed as

$$E = \frac{\sin(n\gamma/2)}{n\gamma/2} = \frac{\sin[(\beta nd/2) \sin\theta]}{(\beta nd/2) \sin\theta}$$

The length  $a$  of the array of discrete sources is

$$a = d(n-1)$$

where  $n$  = number of sources

$d$  = spacing

If  $n \gg 1$ ,  $a \approx nd$ .

$$E = \frac{\sin[(\beta a/2) \sin\theta]}{(\beta a/2) \sin\theta} = \frac{\sin[(a\gamma/2) \sin\theta]}{(a\gamma/2) \sin\theta}$$

where  $a\gamma = \beta a = \frac{2\pi}{\lambda} a$

$$E = \frac{\sin(\gamma'/2)}{\gamma'/2}$$

The null directions  $\theta_0$  of the continuous array pattern are given by

$$\frac{\gamma'}{2} = \pm k\pi$$

where  $k = 1, 2, 3, \dots$

Thus,

$$\theta_0 = \sin^{-1} \pm \left( \frac{k\lambda}{a} \right)$$

For a long array

$$\theta_0 \approx \pm \frac{k}{a_\lambda} \text{ (rad)} \approx \pm \frac{57.3k}{a_\lambda} \text{ (deg)}$$

where  $a_\lambda = \frac{a}{\lambda}$

The beam width between first null ( $k=1$ ) for a long array is then

$$2\theta_{01} \approx \frac{2}{a_\lambda} \text{ (rad)} \approx \frac{115}{a_\lambda} \text{ (deg)}$$

## Long - Wire Antennas

In the frequency band from 2 to 30 MHz long wires (several wavelengths length) supported by suitable towers may be used as efficient antennas. The best known types are the horizontal V antenna, the horizontal rhombic antenna, the vertical V and sloping rhombic antennas, the vertical inverted V or half-rhombic antenna, and the single horizontal-wire antenna. Most long-wire antennas can be operated as resonant antennas, in which case the current on the wire will be a standing wave with the characteristic sinusoidal variation. These antennas usually operate satisfactorily only at a particular frequency and harmonic of this frequency. The input impedance will be highly frequency-sensitive, so only narrow-band operation is possible. Most long-wire antennas can also be operated as traveling wave or nonresonant structures by terminating the far end of the wire in a suitable resistance having a value equal to the characteristic impedance of the antenna viewed as a transmission line. In this mode of operation the useful frequency band can be quite large, with an acceptable impedance match over the whole range of frequencies.

Various types of long-wire antennas are used for commercial shortwave transmission in the frequency range from 2 to 30 MHz when propagation is by means of ionospheric reflection. For these applications the optimum angle of radiation is usually from 10 to 30° relative to the horizontal line in the direction of receiving station.

Since long-wire antennas are located in the presence of ground, the latter has an important

effect on the radiation pattern and must be taken into account in the design of antenna configuration. In general, the design problem is one of obtaining a directive beam at the desired angle relative to the ground for optimum long-distance communication via reflection from the ionosphere, along with acceptable input impedance characteristics that will facilitate matching the antenna to its feed line.

### Radiation from a Resonant Long-wire Antenna



This long-wire antenna is of length  $l = \frac{n\lambda_0}{2}$  with a current distribution  $I(x) = I_0 \sin kx$ . It will be convenient to use the angle  $\psi$  as the polar angle relative to the direction of the wire and to express the radiated electric field as  $E_\psi$ . The field may be found in the same manner as used for the half-wave dipole antenna

$$E(\psi) = \frac{j k_0 Z_0 e^{-j k_0 r}}{4\pi r} \int_{-l}^l [(a_1 \cos \psi - a_2)] I(x') e^{j k_0 x' \cos \psi} dx'$$

The unit vector  $a = a_2$

$$x' = x' a_2$$

$$a_1 \cdot a_2 = \cos \psi$$

$$E(\psi) = \frac{j k_0 Z_0 e^{-j k_0 r}}{4\pi r} \int_{-l}^l (a_2 \cos \psi - a_2) I_0 \sin kx' e^{j k_0 x' \cos \psi} dx'$$

$$a_2 = a_2 \sin \theta \cos \phi + a_2 \cos \theta \cos \phi - a_2 \sin \phi$$

$$\theta = 90^\circ \quad \phi = \psi \quad (\text{for the present case})$$

$$a_2 = a_2 \cos \psi - a_2 \sin \psi \quad \therefore a_2 \cos \psi - a_2 = -a_2 \sin \psi$$

$$\begin{aligned}
 \therefore E_y &= \frac{j k_0 I_0 z_0}{4\pi r} \sin \phi \int_0^{2\pi} \sin k_0 z' e^{-j k_0 r + j k_0 z' \cos \phi} dz' \\
 &= \frac{I_0 z_0}{2\pi r} e^{-j k_0 r + j(n\pi/2)(1+\cos \phi)} \begin{cases} \frac{\sin(\frac{n\pi}{2}) \cos(\frac{n\pi}{2}) \cos \phi}{\sin \phi} & n, \text{ odd} \\ \frac{\cos(\frac{n\pi}{2}) \sin(\frac{n\pi}{2}) \cos \phi}{\sin \phi} & n, \text{ even} \end{cases} \\
 &= -\frac{I_0 z_0}{2\pi r} e^{-j k_0 r + j(n\pi/2)(1+\cos \phi)} (-j)^n \frac{\sin[n\pi \sin^2(\phi/2)]}{\sin \phi}
 \end{aligned}$$

The last expression is obtained by replacing  $\cos \phi$  by  $1 - 2 \sin^2(\frac{\phi}{2})$  and expanding the trigonometric functions.

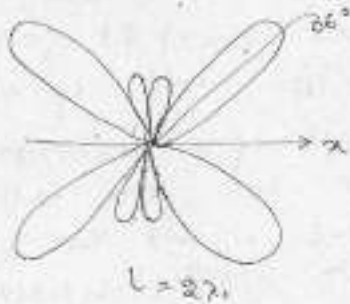
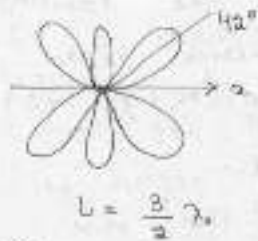
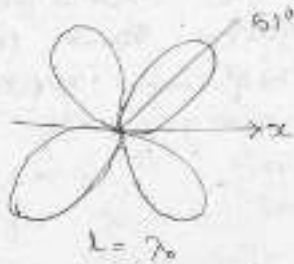

The resultant radiation patterns for  $n=2, 3$  and  $4$  have been shown in the previous figures. The patterns shown should be revolved around the axis of the wire to get the 3-D radiation patterns which are seen to consist of several cones of radiation. In general, the number of lobes or cones formed is equal to  $n$ . The pattern is symmetrical w.r.t. the plane that is perpendicular to the midpoint of the wire. When  $n$  is even, there is a null in the direction  $\phi = \frac{\pi}{2}$ , that is perpendicular to the wire. As  $n$  increases, the lobes become sharper. The first major lobe makes a smaller angle w.r.t. the wire axis as  $n$  increases in value. As the length of the antenna increases, the maximum directivity increases along with the radiation resistance.

## Radiation from a V Antenna

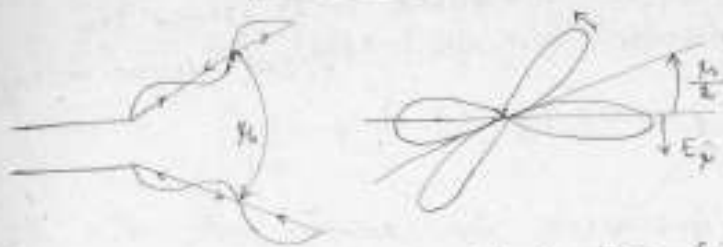

The V antenna shown here consists of two straight-wire antennas arranged so as to subtend an angle  $\alpha$ . The radiation is the superposition of that from each straight-wire section. The objective in the design of V antenna is to choose the angle  $\alpha$  so as to align the two lobes produced by each straight-wire section. If a maximum in the direction of the V antenna and in the plane of the V antenna is desired, then the optimum value for the angle  $\alpha$  is twice the angle that the radiation lobe makes with the wire axis for a straight-wire antenna. If each arm of the V antenna is  $\frac{3\lambda}{2}$  long, this optimum angle is  $24^\circ$ . For  $l = 2\lambda$ , the optimum angle is approximately  $32^\circ$ . The currents on the two arms of the antenna are out of phase, but this is just the condition required for the electric field  $E_p$  radiated by each arm to be in phase in the direction of maximum radiation. The resultant radiation pattern of the V antenna will have a maximum lobe in both the forward and backward directions. Smaller minor lobes will occur in between.

For a horizontal V antenna designed to radiate with a maximum at an angle  $\gamma$  relative to the horizontal plane, the angle  $\alpha$  must be reduced so being the lobe into alignment that this is the case may be seen by recalling that the pattern from a single wire is a cone of radiation so that in order to bring the points

referred to the current maximum, that is  $\frac{1}{2} I_0^2 R_a - P_a$

The long-wire antenna may be fed at one end as shown in the figures below. However, because of the unsymmetrical arrangement the currents in the transmission line will not be balanced, and some radiation will occur from the feed line itself. A more satisfactory feed arrangement is to connect the transmission line at the center of a current loop as close to the midpoint of the antenna as possible. A  $\frac{\lambda_0}{4}$  transformer can be used to transform the radiation resistance to the commonly used 600- $\Omega$  two-wire transmission line. The required impedance of the matching section is given by

$$Z_c = \sqrt{600 R_a}$$

Coincidence, the  $\psi$  angle  $\psi_0$  must be reduced.  
 An alternative procedure is to slope the  $V$  antenna upwards by the required elevation angle  $f$ .

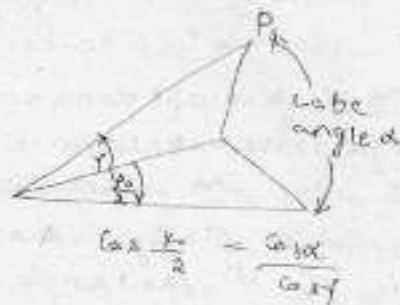
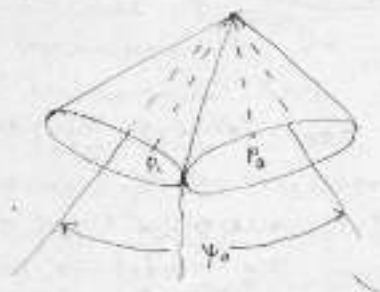

The discussion above applies in general to the rhombic antenna also. The design objective is to choose the angular orientation of each straight wire section so as to align the radiation lobes from the four individual sections in one common direction. In addition, the length of each arm must be chosen so as to obtain in-phase addition of the field radiated by each straight wire section.

### Radiation from a Long-wire Antenna with Traveling Wave Current

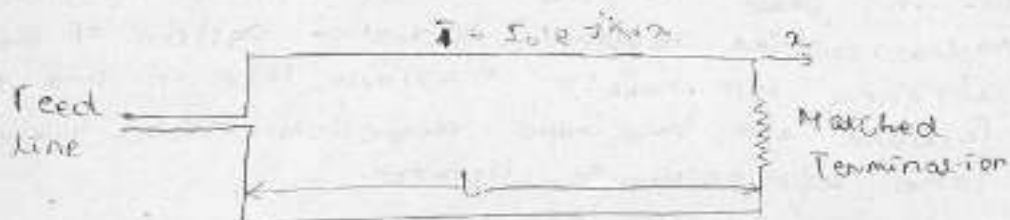

If the far end of the straight wire antenna is terminated in a matched resistance, the current distribution on the antenna can be approximated as a traveling wave of the form  $I = I_0 e^{-jkx}$ . The resultant radiation



Pattern is given by

$$E_y = \frac{j k_0 I_0 z_0}{4 \pi r} \sin \gamma e^{-j k_0 r} \int_0^l e^{-j k_0 z' (1 - \cos \gamma)} dz'$$

$$= \frac{j I_0 z_0}{4 \pi r} e^{-j k_0 [r + (\frac{l}{2})(1 - \cos \gamma)]} \sin \gamma \frac{\sin k_0 l \sin \frac{\gamma}{2}}{\sin^2(\frac{\gamma}{2})}$$

The lobe maxima are determined by

$$\frac{\tan \beta}{\beta} = 2 - \frac{8\beta}{k_0 l}$$

$$\text{where } \beta = k_0 l \sin^2(\frac{\gamma}{2})$$

For  $k_0 l \gg 1$ , the solution is  $\beta = 1.165$ . For other values of  $k_0 l$ , this value can be used for  $\beta$  in the above equation to obtain a corrected value for  $\beta$ . A somewhat more realistic approximation for the current is  $I_0 e^{-\alpha z}$  where the attenuation constant  $\alpha$  accounts for radiation loss from the antenna as the wave propagates along the wire. The attenuation factor  $\alpha$  is small and produces only a small change in the radiation pattern, so we are neglecting this effect.

The radiation pattern for the travelling wave antenna is shown in the following figure for two different antenna lengths  $l$ . The main feature exhibited by these patterns is a major cone of radiation in the forward direction and the absence of a major cone of radiation in the backward direction. As the length of the antenna is increased, the angle of the major cone decreases. If  $l = n \lambda$ , there will be a total of  $2n$  lobes.

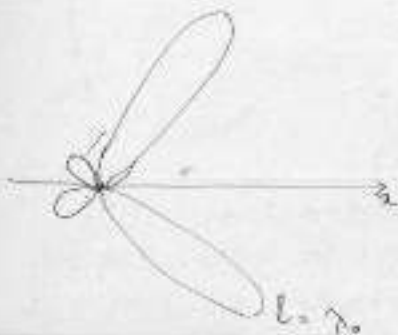

The V antenna can be converted to a traveling-wave antenna by terminating each arm in a matched resistance. The optimum V angle is chosen to align the radiation lobe from each arm in the one common desired direction. The principles involved are the same as those for the resonant V antenna.

The rhombic antenna can also be made into a traveling-wave antenna by inserting a suitable resistance at the vertex furthest away from the feed end. The current on each wire in the rhombus will then be a traveling current wave analogous to that on a transmission line terminated in a matched load. The nominal input resistance of the rhombic antenna is in the range of 700 to 800  $\Omega$ .

The traveling-wave antennas have the advantage that the input impedance is mostly resistive and relatively independent of frequency. Thus these antennas will operate over a fairly broad frequency band. The limiting factor is primarily the misalignment of the lobes that takes place as the frequency is changed.

## Ground Interference Effects

Let us consider the long horizontal wire antenna as shown in the figure below. For radiation at the angle  $\psi$ , the field has a contribution from the direct radiation from the antenna and from radiation reflected from the ground at the angle  $\psi$ . The reflected radiation undergoes a propagation phase delay equivalent to that from the image of the antenna in the ground. If the field radiated by the antenna in free space is

$$E = f(\psi) \frac{e^{-jkr}}{4\pi r}$$

the total field obtained by taking the reflected field into account will be

$$E = f(\psi) \frac{e^{-jkr}}{4\pi r} (1 + \rho e^{j\alpha - j2kh \sin \psi})$$

Where  $\rho e^{j\alpha}$  is the reflection coefficient at the ground and  $2kh \sin \psi$  is the extra propagation distance introduced when the antenna is at a height  $h$ . This expression is seen to be of the same form as that occurring in array theory, with the array factor being

$$F(\psi) = 1 + \rho e^{j\alpha - j2kh \sin \psi}$$

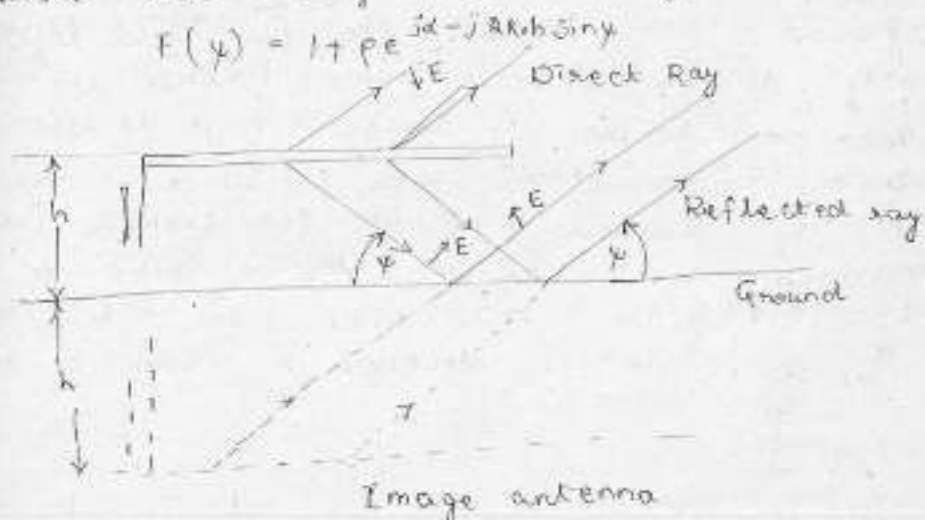

The reflection coefficient depends on the conductivity of the ground, on the grazing angle  $\psi$ , and on whether the field is vertically or

horizontally polarised. For these reasons no simple evaluation of the last equation is not possible. It is often possible to assume that the ground acts as a perfectly conducting surface without serious error. In this case  $\rho=1$  and  $\alpha=\pi$  for horizontal polarization and  $\alpha=0$  for vertical polarization with these idealized conditions the array factor becomes

$$|F(\psi)| = 2 |\sin(kh \sin \psi)| \quad \text{horizontal polarization}$$

$$|F(\psi)| = 2 |\cos(kh \sin \psi)| \quad \text{vertical polarization}$$

For a horizontal wire the reflected field is out of phase with the direct radiation, as shown in the figure in the previous pages that is, the image current is out of phase with the antenna current, so the appropriate array factor to use is  $2 |\sin(kh \sin \psi)|$ , which is approximately equal to  $2 |\sin kh \psi|$  for the range of angles  $\psi$  of interest in practice. The array factor is shown in the figures below for values of  $h$  corresponding to  $\frac{\lambda_0}{4}$ ,  $\frac{\lambda_0}{2}$ , and  $\lambda_0$ . It is readily seen that the reflection from the ground will reduce the far field significantly at low elevation angles unless the antenna height is large enough so that the array factor itself will exhibit a lobe maximum in the desired direction. For example, for a maximum at  $\psi = 20^\circ$  we require  $kh \sin \psi = 90^\circ$  or  $h = 2.25 \lambda_0 / \pi = 0.72 \lambda_0$ . With this height the free-space field is doubled in value by the

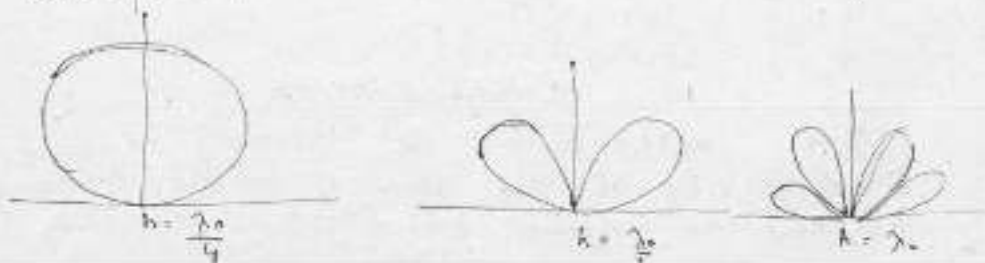

reflected field adding in phase with an actual ground the reflection coefficient  $\rho$  will be less than unity; nevertheless a significant reinforcement of the direct radiation will occur when the antenna height is appropriately chosen.

For surface waves (propagation at frequencies below 2 MHz) horizontally polarized fields are attenuated much more rapidly than vertically polarized fields. For this reason horizontally oriented long-wire antennas are normally not used below 2 MHz. In the short-wave band from 2 to 30 MHz, where propagation is via ionospheric reflection, long-wire antennas are effective and because of their simple structure are commonly used. Rhombic and V antennas also find some applications at frequencies from 30 to 60 MHz.

All VLF, LF and MF antennas, as well as many HF antennas, are made vertically polarized because of the proximity of ground. There are advantages in using horizontally polarized antennas at higher frequencies, especially since most man-made noise has vertical polarization.

## **MODULE-V**

### **USASE OF EM WAVES IN RADAR**

#### **RADAR SYSTEM**

Radar is an electromagnetic system for the detection and location of reflecting objects such as aircraft, ships, spacecraft, vehicles,, people and the natural environment. It operates by radiating energy into space and detecting the echo signal reflected from an object, or target. The reflected energy that is returned to the radar not only indicates the presence of a target, but by comparing the received echo signal with the signal that was transmitted, its location can be determined along with other target-related information. Radar can perform its function at long or short distances and under conditions impervious to optical and infrared sensors. It can operate in darkness, haze, fog, rain and snow. Its ability to measure distance with high accuracy and in all weather is one of its most important attributes.

The basic principle of radar is shown in Fig.1. A transmitter generates an electromagnetic wave (such as a short pulse of sinewave) that is radiated into space by an antenna. A portion of the transmitted energy is intercepted by the target and radiated in many directions. The reradiation directed back towards the radar is collected by the radar antenna, which delivers it to a receiver. The receiver processes it to detect the presence of the target and determine its location. A single antenna is usually used on a time-shared basis for both transmitting and receiving when the radar waveform is a repetitive series of pulses. The range, or distance, to a target is found by measuring the time it takes for the radar signal to travel to the target and return back to the radar. This is called range in radar nomenclature. The target's location in angle can be found from the direction of the narrow-beamwidth radar antenna points when the received echo signal is of maximum amplitude. If the target is in motion, there is a shift in the frequency of the received echo signal due to the Doppler effect. This frequency shift is proportional to the velocity of the target relative to the radar (also called the radial velocity). The Doppler frequency shift is widely used in radar as the basis of separating desired moving targets from fixed unwanted "clutter" echoes reflected from the natural environment such as land, sea or rain. Radar can also provide information about the nature of the target being observed.

The term radar refers to radio detection and ranging. The name reflects the importance placed by the early workers in this field on the need of a device to detect the presence of a target and to measure its range. Although modern radar can extract more information from a target's echo signal than its range, the measurement of range is still one of its most important functions. There are no competitive techniques that can accurately measure long ranges in both clear and adverse weather as well as can radar.

Radars can operate in various modes by radiating different frequencies, with different polarizations. The radar can also employ various waveforms with different pulse widths, pulse repetition frequencies, or other modulations; and different forms of processing different types of clutter, interference, and jamming. The various waveforms and processing need to be selected wisely. A trained operator can fulfill this function, but an

operator can become overloaded. When there are many available system options, the radar can be designed to automatically determine the proper mode of operation and execute what is required to implement it. The mode of radar operation is often changed as a function of the antenna look-direction and/or range, according to the nature of the environments.

Conventional radars generally operate in the microwave region. Operational radars in the past have been at frequencies ranging from about 100MHz to 36 MHz, which covers more than eight octaves. These are not necessarily the limits. Operational HF over-the-horizon radars operate at frequencies as low as a few megahertz. At the other end of the spectrum, experimental millimeter wave radars have been at frequencies higher than 240 GHz. The various frequency ranges of operation as used in radar systems is shown in Table 1.

Table No.1 Part of electromagnetic spectrum used in RADAR applications

Band Designation	Nominal Frequency range	Specific frequency ranges
HF	3-30 MHz	
VHF	30-300 MHz	138-144 MHz 216-225 MHz
UHF	300-1000 MHz	420-450 MHz 850-942 MHz
L	1-2 GHz	1215-1400 MHz
S	2-4 GHz	2300-2500 MHz 2700-3700 MHz
C	4-8 GHz	5250-5925 MHz
X	8-12 GHz	8500-10,680 MHz
Ku	12-18 GHz	13.4-14.0 GHz 15.7-17.7 GHz
K	18-27 GHz	24.05-24.25 GHz
Ka	27-40 GHz	33.4-36 GHz
V	40-75 GHz	59-64 GHz
W	75-110 GHz	76-81 GHz 92-100 GHz
mm	110-130 GHz	126-142 GHz 144-149 GHz 231-235 GHz 238-248 GHz

#### RANGE OF A TARGET:

The most common radar signal, or waveform is a series of short duration, somewhat rectangular-shaped pulses modulating a sinewave carrier. (This is sometimes called a pulse train.) The range to a target is determined by the time  $t_r$  it takes the radar signal to travel to the target and back. As electromagnetic waves travel in free space with the speed

of light, the time for the signal to travel to a target located at range  $R$  and return back to the radar is  $\frac{2R}{c}$ , the range to a target is

$$R_r = \frac{ct_r}{2}$$

This means that one microsecond of round-trip travel corresponds to a distance of 150 meters. (How to measure this time of return? Will autocorrelation of the two signals is useful?)

Maximum unambiguous range:

Once a signal is radiated into space by a radar, sufficient time must elapse to allow all echo signals to return to the radar before the next pulse is transmitted. The rate at which pulses may be transmitted, therefore is determined by the longest range at which targets are expected. If the time between pulses  $t_p$  is too short, an echo signal from a long-range target might arrive after the transmission of the next pulse and be mistakenly associated with that pulse rather than the actual pulse transmitted earlier. This can result in an incorrect or ambiguous measurement of the range. Echoes that arrive after the transmission of the next pulse are called second-time-around echoes (or multiple-time-around echoes if from even earlier pulses). Such an echo would appear to be at a closer range than actual and its range measurement could be misleading if it were not known to be a second-time-around echo. The range beyond which targets appear as second-time-around echoes is the maximum unambiguous range  $R_{un}$ , and is given by

$$R_{un} = \frac{ct_p}{2} = \frac{c}{2f_p}$$

where  $t_p$  is the pulse repetition period and  $f_p = 1/t_p$  is the pulse repetition frequency (prf), usually given in hertz or pulses per second (pps). A plot of the maximum unambiguous range as a function of the prf is shown in Fig.2. The term pulse repetition rate is also used interchangeably with pulse repetition frequency.

## THE SIMPLE FORM OF RADAR EQUATION

The radar equation relates the range of a radar to the characteristics of the transmitter, receiver, antenna, target, and the environment. It is useful not only for determining the maximum range at which a particular radar can detect a target, but it can serve as a means for understanding the factors affecting radar performance. It is also an important tool to aid in radar system design. In this section, the simple form of the radar range equation is derived.

If the transmitter power  $P_t$  is radiated by an isotropic antenna, the power density at a distance  $R$  from the radar is equal to the radiated power divided by the surface area  $4\pi R^2$  of an imaginary surface of radius  $R$ , or



Power density at range  $R$  from an isotropic antenna =  $\frac{P_t}{4\pi R^2}$

Power density is measured in units of watts per square meter. Radars, however, employ directive antennas (with narrow beamwidths) to concentrate the radiated power  $P_t$  in a particular direction. The gain of an antenna is a measure of the increased power density radiated in some direction as compared to the power density that would appear in that direction from an isotropic antenna. The power density at the target from a directive antenna with a transmitting gain  $G$  is

Power density at range  $R$  from a directive antenna =  $\frac{P_t G}{4\pi R^2}$

The target intercepts a portion of the incident energy and reradiates it in various directions. It is only the power density reradiated in the direction of the radar (the echo signal) that is of interest. The radar cross section of the target determines the power density returned to the radar for a particular power density incident on the target. It is denoted by  $\sigma$  and is often called, for short, target cross section, radar cross section, or simply cross section. The radar cross section is defined by the following

Reradiated power density back at the radar =  $\frac{P_t}{4\pi R^2} \cdot \frac{\sigma}{4\pi R^2}$

The radar cross section has units of area, but it can be misleading to associate the radar cross section directly with the target's physical size. The radar antenna captures a portion of the echo energy incident on it. The power received by the radar is given as the product of the incident power density times the effective area  $A_e$  of the receiving antenna. The effective area is related to the physical area by  $A_e = \rho_a A$  where  $\rho_a$  is the antenna aperture efficiency. The received signal power is then

$$P_r = \frac{P_t G}{4\pi R^2} \cdot \frac{\sigma}{4\pi R^2} \cdot A_e = \frac{P_t G A_e \sigma}{(4\pi)^2 R^4}$$

The maximum range of a radar  $R_{\max}$  is the distance beyond which the target cannot be detected. It occurs when the received signal power  $P_r$  just equals the minimum detectable signal  $S_{\min}$ . Substituting  $S_{\min} = P_r$ , and rearranging the terms, we obtain

$$R_{\max} = \left[ \frac{P_t G A_e \sigma}{(4\pi)^2 S_{\min}} \right]^{1/4}$$

This is the fundamental form of the radar equation. It is also called radar range equation. The important parameters are the transmitting gain and the receiving effective area. The transmitter power has not been specified as either the average or the peak power. It depends on how  $S_{\min}$  is defined. Here,  $P_t$  denotes the peak power.

If the same antenna is used for transmitting and receiving, as it usually is in radar, the relationship between the transmit gain  $G$  and the receiver effective area  $A_e$  is

$$G = \frac{4\pi A_e}{\lambda^2} = \frac{4\pi \rho_a A}{\lambda^2}$$

Use of these expressions yield two other forms of radar equation.

$$R_{\max} = \left[ \frac{P_t G^2 \lambda^2 \sigma}{(4\pi)^3 S_{\min}} \right]^{1/4}$$

$$R_{\max} = \left[ \frac{P_t A_e^2 \sigma}{4\pi \lambda^2 S_{\min}} \right]$$

A major advance in radar was made with the invention of the high-power microwave cavity magnetron at the University of Birmingham in England early in WW II. The magnetron dramatically changed the nature of radar as it existed up to that time by allowing the development of radars with small antennas that could be carried on ships and aircraft, and by land-mobile systems. Most countries involved in early radar research recognized the importance of obtaining high power at microwave frequencies and tried to push the conventional magnetron upwards in power.

The use of the Doppler effect in the MTI pulse radar was perfected to separate desired aircraft targets from undesired large underground echoes.

High-power stable amplifiers such as klystron, traveling wave tube, and solid state transistor allowed better application of the Doppler effect, use of sophisticated waveforms, and much higher power than could be obtained with the magnetron.

Highly accurate angle tracking of targets became practical with monopulse radar.

Pulse compression allowed the use of long waveforms to obtain high energy and simultaneously achieve the resolution of a short pulse by internal modulation of the long pulse.

The airborne synthetic aperture radar (SAR) provided high resolution map-like imaging of ground scenes.

Airborne radars using Doppler processing methods gave rise to airborne MTI and pulse Doppler radars, which were able to detect aircraft in the midst of heavy ground clutter.

The electronically steered phased array antenna offered rapid beam steering without mechanical movement of the antenna.

HF over-the-horizon radar extended the detection range for aircraft by a factor of ten, to almost 2000 nmi. Radar became more than a blob detector by extracting information from the echo signal to provide target recognition.

Radar has become an important tool for meteorologist and as an aid for safe efficient air travel by observing and measuring precipitation, warning of dangerous wind shear and other hazardous weather conditions, and for providing timely measurements of the vertical profile of wind speed and direction.

The rapid advances in digital technology made theoretical capabilities with digital signal processing and digital data processing.

The ability of a radar receiver to detect a weak signal is limited by the ever-present noise that occupies the same part of the frequency spectrum as the signal. The weakest signal that can just be detected by a receiver is the minimum detectable signal. Use of the minimum detectable signal is not common to detect echo signals from targets.

Detection of a radar signal is based on establishing a threshold at the output of the receiver. If the receiver output is large enough to exceed threshold, a target is said to be present. If the receiver output is not of sufficient amplitude to cross the threshold, only noise is said to be present. This is called threshold detection.

When a large echo signal from a target is present, it can be recognized on the basis of its amplitude relative to the rms noise level. If the threshold level is set properly, the receiver output should not normally exceed the threshold if a strong target echo signal were present along with the noise. If the threshold level were too low, noise might exceed it and be mistaken for a target. This is called a false alarm. If the threshold were set too high, noise might not be large enough to cause false alarms, but the weak target echoes might not exceed the threshold and would not be detected. When this occurs, it is called a missed detection. The threshold is set according to the classical detection theory.

Almost all radars employ matched filters for maximization of signal to noise ratio. A matched filter does not preserve the shape of the waveform.

The selection of a proper threshold is a compromise that depends on how important it is to avoid the mistake of (1) failing to recognize a target signal that is present (missed detection) or (2) falsely indicating the presence of a target signal when none exists (false alarm). The SNR is a better measure of a radar's detection performance than is the minimum detectable signal.

At microwave frequencies, the noise with which the target echo signal competes is usually generated within the receiver itself. If the radar were to operate in a perfectly noise-free environment so that no external sources of noise accompany the target signal, and if the receiver itself were so perfect that it did not generate any excess noise, there would still be noise generated by the thermal agitation of electrons in the ohmic portion of the receiver input stages. This is called thermal noise. Its magnitude is proportional to the bandwidth and the absolute temperature of the ohmic portions of the input circuit. The available thermal noise power generated at the input of a receiver of bandwidth  $B_n$  at a temperature  $T$  is

$$N = kTB_n$$

where  $k = 1.38 \times 10^{-23}$  J/deg. The term available means that the device is operated with a matched input and a matched load. The bandwidth of a superheterodyne receiver (and almost all radar receivers are of this type) is taken to be that of the IF amplifier (or matched filter).

The bandwidth  $B_n = \frac{\int_0^{\infty} |H(f)|^2 df}{}$

This equation states that the noise bandwidth is the bandwidth of the equivalent rectangular filter whose noise power output is the same as the filter with the frequency response function  $H(f)$ . Noise bandwidth is not the same as the more familiar half power bandwidth. The half power bandwidth is a reasonable approximation for many practical radar receivers. Thus the half power bandwidth  $B$  is usually used to approximate the noise bandwidth  $B_n$ .

The noise power in practical receivers is greater than that from thermal noise alone. The measure of the noise out of a real receiver to that from the ideal receiver with only thermal noise is called noise figure and is defined as

$$F_n = \frac{N_{out}}{kT_0 B G_a}$$

where  $N_{out}$  = noise out of the receiver, and  $G_a$  is the available gain. The factor  $kT_0 = 4 \times 10^{-21}$  W/Hz at room temperature. The available gain  $G_a$  is the ratio of the signal out,  $S_{out}$  to the signal  $S_{in}$  with both the output and the input matched to deliver maximum output power. The input noise  $N_{in}$  in an ideal receiver is equal to  $kT_0 B_n$ . Hence the noise figure can be written as

$$F_n = \frac{S_{in}/N_{in}}{S_{out}/N_{out}}$$

This equation shows that the noise figure may be interpreted as a measure of the degradation of the signal-to-noise ratio as the signal passes through the receiver.

The input signal is

$$S_{in} = \frac{kT_0 B F_n S_{out}}{N_{out}}$$

If the minimum detectable signal  $S_{min}$  is that value of  $S_{in}$  which corresponds to the minimum detectable SNR at the output of the IF,  $\left(\frac{S_{out}}{N_{out}}\right)_{min}$  becomes

$$S_{min} = kT_0 B F_n \left(\frac{S_{out}}{N_{out}}\right)_{min}$$

Use of this gives us another expression for the maximum range of the radar

$$R_{max}^4 = \frac{P_t G A_e \sigma}{(4\pi)^2 kT_0 B F_n (S/N)_{min}}$$

From the above equation we do observe that the minimum detectable signal is replaced in the radar equation by the minimum detectable SNR  $(S/N)_{min}$ . The advantage is

that  $(S/N)_{\min}$  is independent of the receiver bandwidth and noise figure. It can be expressed in terms of the probability of detection and probability of false alarm, two parameters that can be related to the radar user's needs.

The signal-to-noise ratio in the above is that at the output of the IF amplifier, since maximizing the signal-to-noise ratio at the output of the IF is equivalent to the video output where threshold decision is made.

## TRANSMITTER POWER

The power  $P_t$  is the peak pulse power. The average power  $P_{av}$  of a radar is also of interest since it is a more important measure of a radar performance than the peak power. It is defined as the average transmitter power over the duration of the total transmission. If the transmitter waveform is a train of rectangular pulses of width  $\tau$  and constant-pulse-repetition period  $T_p = 1/f_p$ , the average power is related to the peak power by

$$P_{av} = \frac{P_t \tau}{T_p} = P_t \mathcal{D}_p$$

The radar duty cycle can be expressed as  $P_{av}/P_t$  or  $\tau/T_p$ . Pulse radars might typically have duty cycles of from 0.001 to 0.5, more or less. A CW radar has a duty cycle of unity. The duty cycle depends on the type of waveform, the pulse width, whether or not pulse compression is used, and problems associated with range and Doppler ambiguities, and the type of transmitter employed.

Writing the radar range equation in terms of average power, we obtain

$$R_{\max}^4 = \frac{P_{av} G A_e \sigma n E_i(n)}{(4\pi)^2 k T_0 F_n (B\tau) (S/N)_1 f_p}$$

For simplicity, the fluctuation loss  $L_f$  has been set to unity in this equation. The energy per pulse is  $E_p = P_t \tau$  is also equal to  $P_{av}/f_p$ . The radar range equation can also be written as, in terms of energy

$$R_{\max}^4 = \frac{E_p G A_e \sigma n E_i(n)}{(4\pi)^2 k T_0 F_n (B\tau) (S/N)_1} = \frac{E_T G A_e \sigma E_i(n)}{(4\pi)^2 k T_0 F_n (B\tau) (S/N)_1}$$

where  $E_T$  is the total energy of the  $n$  pulses, which equals  $nE_p$ .

## PULSE REPETITION FREQUENCY

The pulse repetition frequency (prf) is determined by the maximum unambiguous range beyond which targets are not expected. The prf corresponding to a maximum unambiguous range  $R_{un}$  is given by  $f_p = 2R_{un}/c$  where  $c$  is the velocity of propagation. There are times, however, when echoes might appear from beyond the maximum unambiguous range, especially for some unusually large target or clutter source (such as a

mountain), or when anomalous propagation conditions occur to extend the normal range of the radar beyond the horizon. Echo signals that arrive at a time later than the pulse-repetition period are called second-time-around echoes. They are also called multiple-time-around echoes, particularly when they arrive from ranges greater than  $2R_{un}$ . The apparent range of these unambiguous echoes can result in error and confusion. Another problem with multiple-time-around echoes is that clutter echoes from ranges greater than  $R_{un}$  can mask unambiguous target echoes at the shorter ranges.

Some types of radars, such as pulse Doppler radars, always operate with a prf that can result in range ambiguities. Range ambiguities are tolerated in a pulse Doppler radar in order to achieve the benefits of a high PRF when detecting moving targets in the midst of clutter. Resolving the range ambiguities is an important part of operation of pulse Doppler radars.

The existence of multiple-time-around echoes cannot be readily recognized with a constant prf waveform. Let us consider three targets labeled A,B and C in the following figure. Target A is within the unambiguous range interval  $R_{un}$ , target B is at a distance greater than  $R_{un}$  but less than  $2R_{un}$ , while target C is greater than  $2R_{un}$  but less than  $3R_{un}$ . Target B is a second-time-around echo; target C is a multiple-time-around echo. When these three pulse repetition intervals, or sweeps, are superimposed on a radar display, the ambiguous echoes look no different from the unambiguous range echo of A. Only the range of A is correct, but it cannot be determined from this display that the other two are not at their apparent range.

Ambiguous-range echoes can be recognized by changing the PRF of the radar. When the PRF is changed, the unambiguous echo (at a range less than  $R_{un}$ ) remains at its true range. Ambiguous-range echoes, however, appear at different apparent ranges for each PRF. An example of how these three echoes might appear on an A-scope is shown in the figure below. A similar effect would be seen on the PPI. Thus the ambiguous target ranges can be readily identified.

If the first pulse repetition frequency  $f_1$  has an unambiguous range  $R_{un1}$  and if the apparent range measured with prf  $f_1$  is denoted  $R_1$ , then the true range is one of the following

$$R_{true} = R_1, \text{ or } (R_1 + R_{un1}), \text{ or } (R_1 + 2R_{un1}), \text{ or } \dots$$

Anyone of these might be the true range. To find which is correct, the prf is changed to  $f_2$  with an unambiguous range  $R_{un2}$ , and if the apparent measured range is  $R_2$ , the true range is one of the following

$$R_{true} = R_2, \text{ or } (R_1 + R_{un2}), \text{ or } (R_1 + 2R_{un2}), \text{ or } \dots$$

The correct range is that value which is the same with the two prfs. In theory, two prfs can resolve the range ambiguity; but in practice, three prfs are often used for increased accuracy and avoiding false values.

The pulse repetition frequency may be changed pulse to pulse, every half beamwidth (with a scanning antenna), or on every rotation of the antenna.

## ANTENNA PARAMETERS

Almost all radars use directive antennas with relatively narrow beamwidths that direct the energy in a particular direction. The antenna is an important part of a radar. It serves to place energy on target during transmission, collect the received echo energy reflected from the target, and determine the angular location of the target. There is always a trade between antenna size and transmitter size when long-range performance is required. If one is small the other must be large to make up for it. This is one reason why large antennas are generally desirable in most radar applications when practical considerations do not limit their physical size. Thus far, the antenna has been thought of as a mechanically steered reflector. Radar antennas can also be electronically steered phased arrays.

**Antenna Gain** The antenna gain  $G(\theta, \phi)$  is a measure of the power per unit solid angle radiated in a particular direction by a directive antenna compared to the power per unit solid angle which would have radiated by an omnidirectional antenna with 100% efficiency. The gain of an antenna is

$$G(\theta, \phi) = \frac{\text{power radiated per unit solid angle at an azimuth } \theta \text{ and an elevation } \phi}{(\text{power accepted by the antenna from the transmitter}) / 4\pi}$$

This is the power gain and is a function of direction. If it is greater than unity in some directions, it must be less than unity in other directions. There is also the directive gain, which has a similar definition except that the denominator is the power radiated by the antenna per  $4\pi$  steradians rather the power accepted from the transmitter. The difference between the two is that the power gain accounts for losses within the antenna. The power gain is more appropriate for the radar equation than the directive again, although there is usually little difference between the two in practical radar antennas, except for the phased array. The power gain and the directive antenna of a radar antenna are usually considered to be the same here. When they are significantly different, then the distinction between the two must be made. The maximum power gain is denoted as  $G$ .

### Effective Area and Beamwidth

The directive gain  $G$  and the effective area  $A_e$  of a lossless antenna are related as

$$G = \frac{4\pi A_e}{\lambda^2} = \frac{4\pi \rho_a A}{\lambda^2}$$

where  $\rho_a$  is the antenna aperture efficiency and  $A$  is the physical area of the antenna.

The gain of an antenna is approximately equal to

$$G \approx \frac{26,000}{\theta_B \phi_B}$$

where  $\theta_B$  and  $\phi_B$  are the azimuth and elevation half-power beam widths, respectively, in degrees. This results in a gain of 44 dB for a one-degree pencil beam. The half-power beamwidth of an antenna also depends on the nature of the aperture illumination and, therefore, the sidelobe level. When no specific information is available regarding the nature of the antenna, the following relation holds good between beamwidth and antenna dimension

$$\theta_B = \frac{65\lambda}{D} \text{ degrees}$$

where the wavelength  $\lambda$  has the same units as the aperture dimension  $D$ . When  $D$  is the horizontal dimension of the antenna, the beamwidth  $\theta_B$  is the azimuth beamwidth; when  $D$  is the vertical dimension,  $\theta_B$  is the elevation beamwidth. The above expression might apply for an antenna with 25 to 28 dB peak sidelobe level.

The half-power beamwidth of an antenna can be measured somewhat accurately, but the antenna gain “is probably one of the least accurate measurements made on an antenna system”.

### Revisit Time

The revisit time is the time that an antenna takes to return to view the same region of space. It usually represents a compromise between (1) the need to collect sufficient energy (a sufficient number of pulses) for the detection of weak targets and (2) the need to have a rapid re-measurement of the location of a moving target so as to quickly determine its trajectory. The revisit time is also called the scan time; and both are inversely related to the rotation rate (rpm) of a scanning antenna. The revisit time of long-range civil air-traffic-control radars are generally in the vicinity of 10 to 12 s, corresponding to an antenna rotation rate of 6 to 5 rpm. Military air-surveillance radars, unlike civil radars, have to detect and track high-speed maneuvering targets. A revisit time of 10 to 12 seconds is too long. Revisit times for long-range military radars are more like 4 seconds (15 rpm). Short-range military radars that must detect and quickly respond to low-flying high-speed targets that pop up over the horizon generally require revisit times of 1 to 2 seconds (60 to 30 rpm), depending on the radar type and design. A small civil marine radar commonly found on boats and ships might have a rotation rate of about 20 rpm (3-s revisit time). High-resolution radars which monitor the ground traffic at major airports, such as the ASDE generally have rotation rates 60 rpm.

### BEAM SHAPE

Radars employ either fan beams or pencil beams. The beam width of the pencil beam shown in diagrams below in the horizontal plane is equal or almost equal to the beam width in the vertical plane. Its beamwidth is generally less than a few degrees; one degree might be typical. It is found in radars that must have accurate location measurement and resolution in both azimuth and elevation. The pencil beam is popular for tracking radars, 3-D radars (rotating air-surveillance radars that obtain elevation angle measurement as well as azimuth and range), and many phased array radars.



The fan-beam antenna shown in figure below has one angle small compared to the other. In air-surveillance radars that use fan beams, the azimuth beamwidth might typically be one or a few degrees, while the elevation beamwidth might be perhaps four to ten times the azimuth beamwidth. Fan beams are found with 2-D (range and azimuth) air-surveillance radars that have to search out a large volume of space. The narrow beamwidth is in the horizontal coordinate so as to obtain a good azimuth angle measurement. The elevation beamwidth is broad in order to obtain good elevation coverage, but at the sacrifice for an elevation angle measurement.

A single pencil beam has difficulty searching out a large angular volume. Employing a number of scanning pencil beams can solve this problem, as is found in some 3-D radars. Sometimes in a 3-D radar a stacked-beam coverage is used in the vertical dimension. This consists of a number of contiguous fixed pencil beams as shown in the following figure. Six to sixteen contiguous beams have been typical in the past.

Usually the shape of a fan beam has to be modified to obtain more complete coverage. An example is the cosecant-squared shaped beam as shown below.

## RECEIVER BANDWIDTH REQUIREMENTS

The bandwidth of the receiver corresponds to the bandwidth of the transmitter and its pulse width. The narrower the pulses, the greater is the IF and video bandwidth required. The RF bandwidth is normally greater than these, as in other receivers. With a given pulse duration  $T$ , the receiver bandwidth may still vary, depending on how many harmonics of the pulse repetition frequency are needed to provide a received pulse having a suitable shape. If vertical sides are required for the pulses in order to give a good resolution, a large bandwidth is required. The bandwidth must be increased if more information about the target is required, but too large a bandwidth will reduce the maximum range by admitting more noise.

The IF bandwidth of a radar receiver is made  $n/T$ , where  $T$  is the pulse duration and  $n$  is a number whose value ranges from under 1 to over 10, depending on the circumstances. Values of  $n$  from 1 to about 1.4 are the most common. Because pulse widths normally range from 0.1 to 10  $\mu$ s, the receiver bandwidth may lie between 200 KHz to over 10 MHz. Bandwidths from 1 to 2 MHz are the most common.

## ANTENNAS AND SCANNING

The majority of radar antennas use dipole or horn-fed paraboloid reflectors, or at least reflectors of a basically paraboloid shape, such as those shown in diagrams below. In each of the cut paraboloid, parabolic cylinder or pillbox reflectors, the beamwidth in the vertical direction will be much worse than in the horizontal direction, but this is immaterial in ground-to-ground or even air-to-ground radars. It has the advantages of allowing a significantly reduced antenna size and weight, reduced wind loading and smaller drive motors.

## ANTENNA SCANNING

Radar antennas are often made to scan a given area of the surrounding space, but the actual scanning pattern depends on the application. In the diagrams below, we show some typical scanning patterns.

The first of these is the simplest but has the disadvantage of scanning in the horizontal plane only. However, there are many applications of this type of scan in searching the horizon, e.g., in ship-to-ship radar. The nodding scan of Fig.b is an extension of this; the antenna is now rocked rapidly in elevation while it rotates more slowly in azimuth, and scanning in both planes is obtained. The system can be used to scan a limited sector or else it can be extended to cover the complete hemisphere. Another system capable of search over the complete hemisphere is the helical scanning system of Fig.c, in which the elevation of the antenna is raised slowly while it rotates more rapidly in azimuth. The antenna is returned to its starting point at the completion of the scanning cycle and typical speeds are a rotation of 6 rpm accompanied by a rise rate of 20°/minute. Finally, if a limited area of more or less circular shape is to be covered, spiral scan may be used as shown in Fig.d.

## AUTOMATIC DETECTION

An operator viewing a PPI display or an A-scope “integrates” in his/her eye-brain combination the echo pulses available from the target. Although an operator in many cases can be as effective as an automatic integrator, performance is limited by operator fatigue, boredom overload and the integrating characteristics of the phosphor of the CRT display. With automatic detection by electronic means, the operator is not depended on to make the detection decision. Automatic detection is the name applied to the part of the radar that performs the operations required for the detection decision without operator intervention. The detection decision made by an automatic detector might be presented to an operator for action or to a computer for further processing.

In many aspects, automatic detection requires much better receiver design than when an operator makes the detection decision. Operators can recognize and ignore clutter echoes and interference that would limit the recognition abilities of some automatic devices. An operator might have better discrimination capabilities than automatic methods for sorting clutter and interference; but the automatic, computer-based decision devices can operate with far greater number of targets than an operator can handle.

Automatic detection of radar signals involves the following:

- Quantization of the radar coverage into range, and maybe angle, resolution cells.
- Sampling of the output of the range-resolution cells with at least one sample per cell, more than one sample when practical
- Analog-to-digital conversion of the analog signals
- Signal processing in the receiver to remove as much noise, clutter echoes, and interference as practicable before the detection decision is attempted.

- Integration of the available samples at each resolution cell.
- Constant-false-alarm rate (CFAR) circuitry to maintain the false-alarm rate when the receiver cannot remove all the clutter and interference
- Clutter map to provide the location of clutter so as to ignore known clutter echoes
- Threshold detection to select target echoes for further processing by an automatic tracker or other data processor
- Measurement of range and angle after the detection decision is made

Track While Scan (Limited Sector Scan) This is the name given to the tracking performed by a rotating-antenna air-surveillance radar which obtains target location updates each time the antenna beam rotates past the target, which might be from about 1 to 12 seconds. The name track while scan for this type of a radar is now seldom used since almost all modern air-surveillance radars provide the equivalent with what is called automatic detection and track (ADT). This type of antenna is used to scan a relatively narrow angular sector, usually in both azimuth and elevation. It combines the search function and the track function. Scanning may be performed with a single narrow-beamwidth pencil beam that might cover a rectangular sector in a raster fashion. Scanning can also be performed with two orthogonal fan beams, one hat scans in the azimuth and the other in elevation. TWS radars have been used in airport landing radars, airborne interceptors; and air-defense systems.

A difference between a continuous tracker and the TWS radar is that the angle-error signal in a continuous tracker is used in a closed-loop servo system to control the pointing of the antenna beam. In the TWS radar, however, there is no closed-loop positioning of the antenna. Its angle output is sent directly to a data processor. Another significant difference is that the TWS radar can provide simultaneous tracks on a number of targets within the sector of coverage, while the continuous tracker observes only a single target, which is why it is sometimes called a single-target tracker. With comparable transmitters and antennas, the energy available to perform tracking is less in a TWS radar than a STT since the TWS shares its radiated energy over an angular sector rather than concentrate it in the direction of a single target. In airborne-interceptor applications, the TWS radar might be preferred when multiple targets have to be maintained in track and the tracking accuracy only has to be good enough to launch missiles which contain their own guidance systems to home on the target. On the other hand, if highly accurate tracking is needed, a single-target tracker might be preferred.

Limited sector-scan TWS radars have been used in Precision Approach radars (PAR) or Ground-Controlled Approach (GCA) systems that guide aircraft to a landing. These radars allow a ground controller to direct an aircraft to a safe landing in bad weather by tracking it as it lands. The ground controller communicates to the pilot directions to change his or her heading up, down, right, or left. In the control of aircraft landing, fan beams have been used which are electromechanically scanned over a narrow sector at a rate of twice per second. The azimuth sector that is scanned might be  $20^{\circ}$  and the elevation sector  $6^{\circ}$  or  $7^{\circ}$ . Landing radars using limited-scan phased array antennas, such as the AN/TPS-19, operate differently than scanning fan beams

since they electronically scan a pencil beam over a region of  $20^{\circ}$  in azimuth and  $15^{\circ}$  in elevation at a rate of twice per second. The AN/TPN-19 used multiple beams to obtain a monopulse angle measurement. Being a phased array, the AN/TPN-19 could simultaneously track up to six aircraft at a 20-Hz data rate. In the past, radars for the control of landing aircraft have been mainly used by the military. Civilian pilots prefer to use landing systems in which control of landing is in the aircraft's cockpit rather than from a voice originating from the ground.

TWS radars have also been used successfully for the control of weapons in surface-to-air missile systems for both land and ship-based air defense, especially by the former Soviet Union.

Generally TWS systems using fan beams have some limitations compared to systems that operate with one or more pencil beams. The fan-beam system can see more rain and surface clutter, it is more vulnerable to electronic countermeasures, and there might be problems with associating multiple targets that appear in the two beams.

The advantage of TWS compared to a continuous tracker is that multiple targets can be tracked. Because it shares its energy over a region of space, the TWS radar needs to have a larger transmitter to obtain the same detection and tracking capabilities of a STT that dwells continuously on a single target. If the target's angle is found from the centroid of the angle measurements obtained as the TWS antenna beam scans past the target, inaccuracies can occur if the target signal fluctuates in amplitude. TWS radars are also more vulnerable to angle jamming than are continuous trackers. TWS radars can use monopulse angle measurements in an open-loop manner, similar to a phased-array. Since the monopulse measurement is not made with closed-loop tracking, a TWS radar should not experience the wild fluctuations in angle caused by glint when there are multiple scatterers within the resolution cell or when there is multipath at low elevation angles.

## MONOPULSE TRACKING

A monopulse tracker is defined as one in which information concerning the angular location of a target is obtained by comparison of signals received in two or more simultaneous beams. A measurement of angle may be made on the basis of a single pulse; hence the name monopulse. In practice, however, multiple pulses are usually employed to increase the probability of detection, improve the accuracy of the angle estimate, and provide resolution in Doppler when necessary. By making an angle measurement based on the signals that appear simultaneously in more than one antenna beam, the accuracy is improved compared to time-shared single-beam tracking systems (such as conical scan or sequential lobing) which suffer degradation when the echo signal amplitude changes with time. Thus the accuracy of monopulse is not affected by amplitude fluctuations of the target echo. It is the preferred tracking technique when accurate angle measurements are required.

The monopulse angle method may be used in a tracking radar to develop an angle error signal in two orthogonal angle coordinates that mechanically drive the boresight of the tracking antenna using a closed-loop servo system to keep the boresight positioned in the direction of the moving target. In radars such as the phased-array, angle measurements can be obtained in an open-loop fashion by calibrating the error-signal voltage in terms of angle.

There are several methods by which a monopulse angle measurement can be made. The most popular by far has been the amplitude-comparison monopulse which compares the amplitudes of the signals simultaneously received in multiple squinted beams to determine the angle. When the term monopulse is used by itself with no other description, it generally refers to the amplitude-comparison version.